

TOLLING REGULATIONS FOR THE MOTORWAYS AND EXPRESSWAYS OF AUSTRIA

**Formally approved in accordance with section 14(2) Federal Road Tolls Act 2002 and,
with regard to Tolling Regulations
Part A II, adopted by decree by the Federal Minister of Climate Action, Environment,
Energy, Mobility, Innovation and Technology in agreement with the Federal Minister of
Finance**

**GZ: 325.009/1-I/K2-2003
last amendment
2021-0,626,278**

Valid from 19 October 2021

Version 64

Contents

CONTENTS	2
PREAMBLE.....	8
PART A I: TOLLING REGULATIONS FOR VEHICLES WITH A MAXIMUM TOTAL WEIGHT OF UP TO 3.5 T	10
1 GENERAL REGULATIONS	10
1.1 DEFINITION OF TERMS	10
1.2 SCOPE OF APPLICATION.....	10
1.3 MANDATORY VIGNETTE	11
1.3.1 Road network subject to tolls	11
1.3.2 Signing	12
1.3.3 Exceptions from vignette obligation.....	13
1.4 VIGNETTE PRICES.....	16
1.5 DURATION OF ENTITLEMENT OF USE	16
1.5.1 Annual toll sticker.....	16
1.5.2 Two-month vignette	16
1.5.3 Ten-day vignette	17
1.6 RELIEF MEASURES	17
1.6.1 Free vignettes for people with disabilities.....	17
1.6.2 Right to reimbursement of vignettes issued for disabled persons.....	18
1.7 OBLIGATIONS	18
1.8 MONITORING COMPLIANCE WITH THE VIGNETTE OBLIGATION.....	19
1.8.1 Inspection by road inspection authorities and toll enforcement officers	19
1.8.2 Automatic vignette monitoring.....	21
1.9 TOLL EVASION.....	22
1.9.1 Penalties for toll evasion	22
1.9.2 Non-imposition of a penalty.....	22
1.9.3 Substitute toll	22
1.10 VIOLATION OF THE OBLIGATION TO STOP.....	25
1.11 DATA PROTECTION AND DATA SECURITY	25
1.12 JURISDICTION AND APPLICABLE LAW	25
1.13 RESPONSIBILITY AND CUSTOMER SERVICE (ASFINAG Service Center)	26
2 FURTHER REGULATIONS WHEN USING A TOLL STICKER.....	26
2.1 SALE OR DISTRIBUTION OF THE TOLL STICKER	26
2.2 ATTACHING THE TOLL STICKER.....	26
2.2.1 Where and how to attach the toll sticker.....	26
2.2.2 Permissibility of carrying an unattached toll sticker in the vehicle.....	27
2.3 TOLL STICKER REPLACEMENT	27
3 FURTHER REGULATIONS WHEN USING A DIGITAL VIGNETTE.....	28
3.1 AVAILABILITY OF THE DIGITAL VIGNETTE	28
3.2 OBTAINING THE DIGITAL VIGNETTE.....	28
3.2.1 Obtaining the digital vignette in the Webshop and with the ASFINAG app	28
3.2.2 Purchase of the digital vignette at a vending machine.....	29
3.2.3 Obtaining the digital vignette from points of sale	30
3.2.4 Means of payment	31
3.2.5 Further Services	31
3.2.6 Terms of use.....	33
3.3 RIGHT OF WITHDRAWAL	33
3.4 SPECIFICS FOR ENTREPRENEURS CONCERNING THE PURCHASE OF A DIGITAL VIGNETTE	34
3.5 POSSIBLE CHANGES BEFORE THE BEGINNING OF VALIDITY.....	34
3.6 RE-REGISTRATION FROM THE BEGINNING OF VALIDITY	35

3.6.1	Conditional changes in the ASFINAG Webshop	36
3.6.2	Changes at the ASFINAG Service Center	37
3.6.3	Change of license plate number at toll stations and selected points of sale	38
PART A II: TOLLING REGULATIONS FOR VEHICLES WITH A MAXIMUM TOTAL WEIGHT OF UP TO 3.5 T FOR EXISTING SECTION TOLLS ON THE AUSTRIAN MOTORWAY AND EXPRESSWAY NETWORK: A 9, A 10, A 11, A 13, S 16		40
1	GENERAL REGULATIONS	40
1.1	DEFINITION OF TERMS	40
1.2	SCOPE OF APPLICATION	40
1.3	ROAD SECTIONS ON WHICH TOLLS ARE LEVIED	41
1.3.1	Names of the section toll segments and toll stations	41
1.3.2	Signing	42
1.4	JURISDICTION AND APPLICABLE LAW	42
1.5	RESPONSIBILITY AND CUSTOMER SERVICE (ASFINAG Service Center)	42
2	OBLIGATION TO PAY THE SECTION TOLL	42
2.1	MIXED TOLL LANE OPERATION	42
2.2	OPEN TOLL LANE OPERATION;	42
2.2.1	Open toll lane operation on A10, A11, A13 and S16	42
2.2.2	Open toll lane operation on A 9	43
2.2.3	Special obligations to cooperate A 9	44
2.3	EXEMPTIONS FROM THE TOLL OBLIGATION	44
2.3.1	Permanent exemptions	44
2.3.2	Temporary exceptions	45
2.3.2.1	Exceptions for humanitarian aid transports	45
2.3.2.2	Exceptions at the request of the Federal Ministry of the Interior (BM.I) in the context of state crisis and disaster control management or international disaster aid	46
3	TOLL RATES	46
3.1	STANDARD TOLL RATES	46
3.1.1	A 9 Gleinalm and A 9 Bosruck	46
3.1.2	A 10 Tauern/Katschberg	47
3.1.3	A 11 Karawanken	47
3.1.4	A 13 Brenner	47
3.1.5	S 16 Arlberg road tunnel	47
3.2	TYPE OF RATES	48
3.2.1	Single trip	48
3.2.2	Annual card (without vignette credit)	48
3.2.3	Annual card with vignette credit	48
3.2.4	Annual card for commuters	48
3.2.5	Annual card for disabled drivers	48
3.2.6	Annual card for disabled drivers on the A 13	49
3.2.7	Monthly card for the A 13	49
3.2.8	Resident's card for the A 13	49
3.2.9	14-trip monthly card for the A 11	50
3.3	LOSS OF LICENSE PLATE NUMBER RELATED CARDS	50
4	PAYMENT METHODS	50
4.1	PAYMENT AT THE TOLL STATION	50
4.2	PURCHASE IN ADVANCE	50
4.2.1	Purchase in the Webshop and the ASFINAG App: Payment in advance - Pre-Pay	50
4.2.2	Pre-registration in the Webshop and the ASFINAG App: Retroactive payment - Digital Route Toll Flex	51
4.2.3	Purchase at the vending machine	51
4.2.4	Purchase at sales points	51
4.2.5	Means of payment	51
4.3	ADDITIONAL SERVICES ("My Account")	52

4.3.1	General services.....	52
4.3.2	Digital subscription in the personal user account ("My Account")	52
4.3.3	Retroactive payment of single journeys (Digital Route Toll Flex) in the personal user account ("My Account")	53
4.4	Terms of use.....	53
4.5	RIGHT OF WITHDRAWAL	53
4.6	SPECIFICS FOR ENTREPRENEURS.....	54
4.7	POSSIBLE CHANGES	54
4.8	RE-REGISTRATION FROM THE BEGINNING OF VALIDITY	55
5	DATA PROTECTION AND DATA SECURITY	57
6	MONITORING CORRECT PAYMENT OF THE SECTION TOLL.....	57
6.1	TOLL ENFORCEMENT OFFICERS	57
6.2	CONFISCATION OF LICENSE PLATE NUMBER RELATED CARDS.....	59
7	TOLL EVASION.....	59
7.1	PENALTIES FOR TOLL EVASION.....	59
7.2	NON-IMPOSITION OF A PENALTY	59
7.3	SUBSTITUTE TOLL.....	59
7.3.1	Method of payment.....	59
7.3.2	Substitute toll rate	60
7.3.3	Continued journey.....	62
7.3.4	Payment of the substitute toll	62
8	VIOLATION OF THE OBLIGATION TO STOP.....	62
PART B: TOLLING REGULATIONS FOR TWIN-TRACK VEHICLES WITH A MAXIMUM TOTAL WEIGHT OF MORE THAN 3.5 T		63
1	GENERAL INFORMATION.....	63
2	SCOPE OF APPLICATION.....	63
3	TOLL OBLIGATION.....	64
3.1	Road network subject to tolls	64
3.1.1	Areas with existing road tolls.....	65
3.1.2	The toll obligation in areas around road works.....	67
3.1.3	Temporary entries and exits in accordance with section 26(2) Federal Highways Act... ..	67
3.2	Signing	67
3.3	Exemptions from the toll obligation	68
3.3.1	Permanent exemptions	68
3.3.2	Temporary exceptions	69
3.3.3	Special exemptions.....	71
4	TOLL TARIFFS.....	71
5	REGISTERING WITH AND DEREGISTERING FROM THE TOLL SYSTEM.....	73
5.1	General information	73
5.2	Declaration of the relevant EURO emission class	74
5.2.1	Declaration of the EURO emission class.....	75
5.2.2	Checking the requested EURO emission class/allocation to a toll rate group (verification).....	76
5.2.3	Documents that are suitable for proving the EURO emission class of a vehicle	81
5.3	GO points of sale	82
5.4	Processing fee.....	82
5.5	Payment Procedure	82
5.5.1	General information	82
5.5.2	About the postpaid procedure	83
5.5.3	About the prepaid procedure.....	83
5.6	Data storage	83
5.6.1	General information	83

5.6.2	Obligation to inform ASFINAG immediately of changes in the data to be stored in accordance with section 5.6.1	84
5.6.3	SALE of a vehicle	85
5.6.4	Vehicle RENTAL.....	86
5.6.5	Interchangeable license plates.....	88
5.6.6	Test drivers and motor trader trips	88
5.7	Provisions relating to the GO-Box.....	91
5.7.1	General information	91
5.7.2	GO-Box: period of validity, guarantee, exchange, bearing of costs, and recall	92
5.7.3	Theft, loss, and deactivation of the GO-Box.....	93
5.7.4	Deregistration, returning the GO-Box, and the lapse of toll credit.....	94
5.7.5	Transportation of GO-Boxes without the obligation to pay the toll obligation	95
6	ITEMISED TOLL INFORMATION SHEETS AND COLLECTIVE INVOICE STATEMENTS	95
6.1	Itemised toll information sheets.....	95
6.2	Collective invoice statements.....	95
7	SUBSEQUENT PAYMENT OF THE TOLL	96
7.1	Retroactive payment at GO points of sale/toll enforcement officers	96
7.2	Central retroactive payment in the event of use of a too low category or toll rate group	97
7.3	Retroactive settlement	98
8	OBLIGATIONS OF MOTOR VEHICLE DRIVERS.....	98
8.1	Correct installation of the GO-Box.....	98
8.2	Correct operation of the GO-Box	99
8.2.1	Example for GO-box	99
8.2.2	Declaring and setting the vehicle category (not applicable for buses and motor caravans)	99
8.2.3	Declaring and setting the vehicle category (buses and motor caravans)	100
8.2.4	Checking that the GO-Box is in working order.....	100
9	MONITORING ADHERENCE TO THE TOLL OBLIGATION.....	103
9.1	Toll enforcement officers and their powers.....	103
9.2	Toll enforcement officers' identification cards.....	105
9.3	Toll enforcement officers' vehicles	105
10	TOLL EVASION.....	105
10.1	Penalties for toll evasion	105
10.2	Non-imposition of a penalty.....	106
10.3	Substitute toll	106
10.3.1	Method of payment	106
10.3.2	Substitute toll rate	107
10.3.3	Initiation of administrative penal proceedings.....	108
11	11 DATA PROTECTION AND DATA SECURITY	108
12	VIOLATION OF THE OBLIGATION TO STOP.....	108
13	PLACE OF JURISDICTION AND APPLICABLE LAW.....	108
14	RESPONSIBILITY AND CUSTOMER SERVICE (ASFINAG SERVICE CENTER) .	108
15	SPECIAL PROCEDURES IN CONJUNCTION WITH MOTOR VEHICLES POWERED PURELY BY ELECTRIC OR HYDROGEN FUEL CELL	109
	PART C: INTEROPERABILITY	110
1	THE AUTHORISATION OF ON-BOARD UNITS USED FOR THE SWISS LSVA TOLL SYSTEM	110
1.1	General information	110
1.2	Provisions relating to the on-board unit.....	110
1.3	Registration	111
1.3.1	Registration procedure.....	111
1.3.2	Declaration of the EURO emission class and changing data.....	111

1.4	Data exchange.....	111
1.5	Obligations of motor vehicle drivers	112
1.5.1	The correct installation and operation of the on-board unit and the setting of the category in the on-board unit.....	112
1.5.2	Checking that the on-board unit is in working order	112
1.6	Signals emitted by the on-board unit.....	112
1.7	Log out	113
2	SECOND CONTRACT INTEROPERABILITY WITH GERMANY ("TOLL2GO")	113
2.1	General information	113
2.2	Requirements for using the service in Austria	113
2.3	Registration	114
2.3.1	Registering for the first time	114
2.3.2	Switching from an Austrian GO-Box to the TC OBU.....	116
2.3.3	Declaration of the relevant EURO emission class	117
2.3.4	Vehicle declaration	118
2.4	Right to refusal.....	118
2.5	The storage and exchange of data.....	118
2.6	Data changes	119
2.7	The sale or rental of vehicles	120
2.8	Provisions relating to the TC OBU	120
2.9	GO points of sale	120
2.10	Deregistering the TC OBU	121
2.11	Subsequent payment of the toll.....	121
2.12	Obligations of motor vehicle drivers	122
2.12.1	The correct installation and operation of the TC OBU and setting the category in the TC OBU	122
2.12.2	Checking that the TC OBU is in working order	122
2.12.3	Acoustic signals emitted by the TC OBU.....	122
3	THE AUTHORISATION OF ON-BOARD UNITS ACTIVATED FOR THE EASYGO+ SERVICE	124
3.1	General information	124
3.2	Provisions relating to the on-board unit (hereinafter referred to as the EasyGo+ OBU).	124
3.3	Registering with and de-registering from the EasyGo+ service	125
3.4	The storage and exchange of data.....	125
3.4.1	Correct toll payment with the EasyGo+ OBU	125
3.4.2	Incorrect toll payment with the EasyGo+ OBU	126
3.5	Obligations.....	126
3.5.1	Vehicle declaration	126
3.5.2	Installation and operation of the EasyGo+ OBU.....	126
3.5.3	Declaring and setting the category.....	127
3.5.4	Checking that the EasyGo+ OBU is in working order	127
3.5.5	Acoustic signals emitted by the EasyGo+ OBU.....	127
3.6	Subsequent payment of the toll.....	128
3.7	Responsibilities and services	128
3.7.1	Toll service providers.....	128
3.7.2	GO points of sale	128
3.7.3	ASFINAG SERVICE CENTER (ASC)	129
3.7.4	Special features	129
3.8	Use of the "local" Austrian GO-Box.....	129
4	THE AUTHORISATION OF ON-BOARD UNITS FOR TOLL PAYMENT IN AUSTRIA WITHIN THE SCOPE OF THE "EUROPEAN ELECTRONIC TOLL SERVICE" ("EETS")... ..	130
4.1	European Electronic Toll Service (EETS).....	130
4.2	Provisions relating to the on-board unit (EETS OBU).....	130

4.3	Registration with and de-registration from EETS.....	131
4.4	The storage and exchange of data.....	131
4.4.1	Correct toll payment with the EETS OBU.....	131
4.4.2	Incorrect toll payment with the EETS OBU.....	132
4.5	Obligations.....	132
4.5.1	Vehicle declaration	132
4.5.2	Installation and operation of the EETS OBU	132
4.5.3	Declaring and setting the category.....	132
4.5.4	Checking that the EETS OBU is in working order	133
4.5.5	Acoustic signals emitted by the EETS OBU	133
4.6	Subsequent payment of the toll.....	134
4.7	Responsibilities and services	134
4.7.1	EA.....	134
4.7.2	GO points of sale	135
4.7.3	ASFINAG Service Center (ASC).....	135
4.7.4	Special features	135
4.8	Use of the Austrian GO-Box.....	135

PREAMBLE

According to the usufruct contract concluded on the basis of the ASFINAG-Enabling Act 1997, BGBl. I No. 113/1997, Autobahnen- und Schnellstraßen- Finanzierungs-Aktiengesellschaft (ASFINAG) was transferred the rights of usufruct for all motorways and expressways. ASFINAG therefore has the right to collect a toll from all users of federal roads and sections of federal roads that are subject to the rights of usufruct. ASFINAG is a company incorporated under the ASFINAG act, BGBl. No. 591/1982, the shares of which are wholly owned by the Republic of Austria:

1. In accordance with the provisions of the Federal Road Tolls Act 2002 (BStMG), BGBl. I No. 109/2002 (unless expressly indicated otherwise, all references to Acts relate to the respective Act as amended), ASFINAG has the right to collect either a time-related toll or a distance-related toll from the users of all motorways and expressways, depending on the maximum total weight of the vehicle. A toll obligation is also levied on all areas that are part of a federal road in accordance with section 3 of the Federal Highways Act 1971. In accordance with section 14(1) BStMG, ASFINAG is obliged to draw up Tolling Regulations containing provisions governing the use of motorways and expressways on which tolls are levied. The present Tolling Regulations contain the following:
 - General provisions for the payment of time-related tolls for motor vehicles whose maximum permissible total weight does not exceed 3.5 tonnes (Part A I of these tolling regulations), whereby the collection or performance of the operational tasks associated with this (Service Center for vignettes, vignette production, vignette distribution, etc.) by ASFINAG Maut Service GmbH, Alpenstraße 99, A-5020 Salzburg, Alpenstraße 99, A-5020 Salzburg, or by ASFINAG Service GmbH, Traunuferstraße 9, A-4052 Ansfelden and ASFINAG Alpenstraße GmbH, Rennweg 10 A, A-6020 Innsbruck are performed on behalf of and for the account of ASFINAG, and
 - General provisions for the payment of the distance-related tolls for motor vehicles whose maximum permissible total weight exceeds 3.5 tonnes (Part B of these tolling regulations), whereby the fully electronic toll system for collecting distance-related tolls is operated by ASFINAG Maut Service GmbH, Alpenstraße 99, A-5020 Salzburg, Austria, and the performance of the associated operative tasks is carried out by ASFINAG Maut Service GmbH, Alpenstraße 99, A-5020 Salzburg, or ASFINAG Service GmbH, Traunuferstraße 9, A-4052 Ansfelden and ASFINAG Alpenstraße GmbH, Rennweg 10 A, A-6020 Innsbruck in the name of and for the account of ASFINAG.
2. By decree of the Federal Minister for Climate Protection, Environment, Energy, Mobility, Innovation and Technology in agreement with the Federal Minister of Finance to ASFINAG, the general provisions and toll payments with regard to section tolls on the routes of the A 9, A 10, A 11, A 13 and S 16 are issued. The legal basis for the collection of section tolls as set out in § 32 BStMG will be presented below according to the existing toll sections.

A 9 Pyhrn motorway: The toll will be collected between the Spital/Pyhrn and Ardning junctions and between the St. Michael intersection and the Übelbach junction. This toll section is divided into two separate subsections and includes the Bosruck and Gleinalm tunnels. The authorisation to collect a charge is regulated by section 2(1) of the Pyhrn Motorway Financing Act, BGBl. No. 479/1971.

A 10 Tauern motorway: The toll will be collected between the Flachau and Rennweg junctions. This toll section includes the Tauern and Katschberg tunnels. The authorisation to collect a charge is regulated by section 2(1) of the Tauern Motorway Financing Act, BGBl. No. 115/1969.

A 11 Karawanken motorway: The toll will be collected on the A 11 between the St. Jakob/Rosental junction and Austrian border (Karawanken tunnel). The authorisation to collect a charge is regulated by Article 12 of the aforementioned Treaty and section 2 of the Karawanken Motorway Financing Act, BGBl. No. 442/1978.

A 13 Brenner motorway: The toll will be levied between the Innsbruck-Amras/Innsbruck-Wilten intersection and the national border on the Brenner Pass. The authorisation is governed by § 1 para.1 of the Act on the financing of the Innsbruck-Brenner motorway, Federal Law Gazette No. 135/1964.

S 16 Arlberg expressway: The toll will be collected between the St. Anton am Arlberg and Langen/Arlberg junctions. This section toll segment includes the Arlberg tunnel. The authorisation to collect a charge is regulated by section 2(1) of the Arlberg Expressway Financing Act, BGBl. No. 113/1973.

The road section toll will be collected by ASFINAG Maut Service GmbH, Alpenstraße 99, A-5020 Salzburg, Austria, on behalf of and for the account of ASFINAG. Tolls are collected for motor vehicles whose maximum permissible total weight does not exceed 3.5 tonnes in accordance with Part A II of these tolling regulations. For motor vehicles with a maximum permissible total weight of more than 3.5 tonnes, the legal basis is the Federal Roads Toll Act 2002 and the provisions of Part B of these tolling regulations apply.

3. Part A I, Part B and Part C of these tolling regulations were approved in accordance with Section 14 para. 2 BStMG by the Federal Minister for Climate Protection, Environment, Energy, Mobility, Innovation and Technology in agreement with the Federal Minister of Finance, while Part A II of these tolling regulations was issued to ASFINAG by the Federal Minister for Climate Protection, Environment, Energy, Mobility, Innovation and Technology in agreement with the Federal Minister of Finance.

Insofar as personal designations are used in the following only in the masculine form, they refer to men and women in the same way.

PART A I: TOLLING REGULATIONS FOR VEHICLES WITH A MAXIMUM TOTAL WEIGHT OF UP TO 3.5 T

1 GENERAL REGULATIONS

1.1 DEFINITION OF TERMS

- **toll sticker:** If in the following the term “vignette“ is being used, it covers the toll sticker as well as the digital vignette.
- **valid vignette:** The toll is properly paid if either a valid toll sticker (corresponding to the type of vehicle) is properly affixed to the vehicle (exception see section 2.2.2) or a valid digital vignette (corresponding to the type of vehicle) is properly registered in the toll system for the time period of use of the road network subject to toll payment.
- **order confirmation:** The document issued when a digital vignette has been obtained (registration in the toll system). This document particularly shows data of the license plate number registered in the toll system, vehicle type, validity period as well as the product-ID, which serves to clearly identify the digital vignette.
- **allonge:** The lower section of the toll sticker (backing paper/ toll sticker tab).
- **type of vignette:** A vehicle-related differentiation between vignettes for single-track vehicles and twin-track vehicles with a maximum total weight of up to 3.5 t.
- **ASFINAG app:** If in the following the term ASFINAG app is being used, the ASFINAG app “Unterwegs” is meant.
- **vignette registry:** This term is used to define the publicly accessible registry on www.asfinag.at, which can be visited by any person without any costs, to view whether a license plate number is already registered in the toll system and therefore owns a digital vignette or a digital section toll ticket and for what time period it is valid.
- **Vehicle type:** Hereby a differentiation between single-track vehicles and twin-track vehicles with a maximum total weight of up to 3.5 t is made.
- **digital subscription:** A digital subscription is an unlimited obtainment of digital annual vignettes or digital annual cards similar to a subscription contract.

1.2 SCOPE OF APPLICATION

Tolling Regulations Part A I applies to all vehicles with a maximum total weight of up to 3.5 t. These vehicles are liable for a time-related toll (vignette). Unless expressly indicated otherwise, all references to individual sections contained in Part A I of the Tolling Regulations relate specifically to sections in Part A I of the Tolling Regulations.

According to § 10 para. 3 last sentence of the BStMG [Federal Road Tolls Act], motor vehicles with three wheels are considered as single-track motor vehicles.

No time-related toll must be paid for trailers being towed by twin-track vehicles with a maximum total weight of up to 3.5 t or for sidecars attached to single-track vehicles.

Drivers of twin-track vehicles that have not yet been registered and carry transfer license plates are obliged to pay the time-related toll as long as the service weight of their vehicle does not exceed

3.5 t. When driving a vehicle with transfer license plates, drivers must carry a copy of the vehicle's logbook or evidence of the service weight of the vehicle provided by the car manufacturer or their authorised representative in accordance with section 29(2) of the Motor Traffic Act. If evidence of this kind cannot be presented on request, the twin-track vehicle in question shall be considered a vehicle with a service weight of more than 3.5 t.

1.3 MANDATORY VIGNETTE

1.3.1 Road network subject to tolls

Unless exemptions apply, a time-related toll must be paid for vehicles that are liable for the toll for the use of the motorways and expressways:

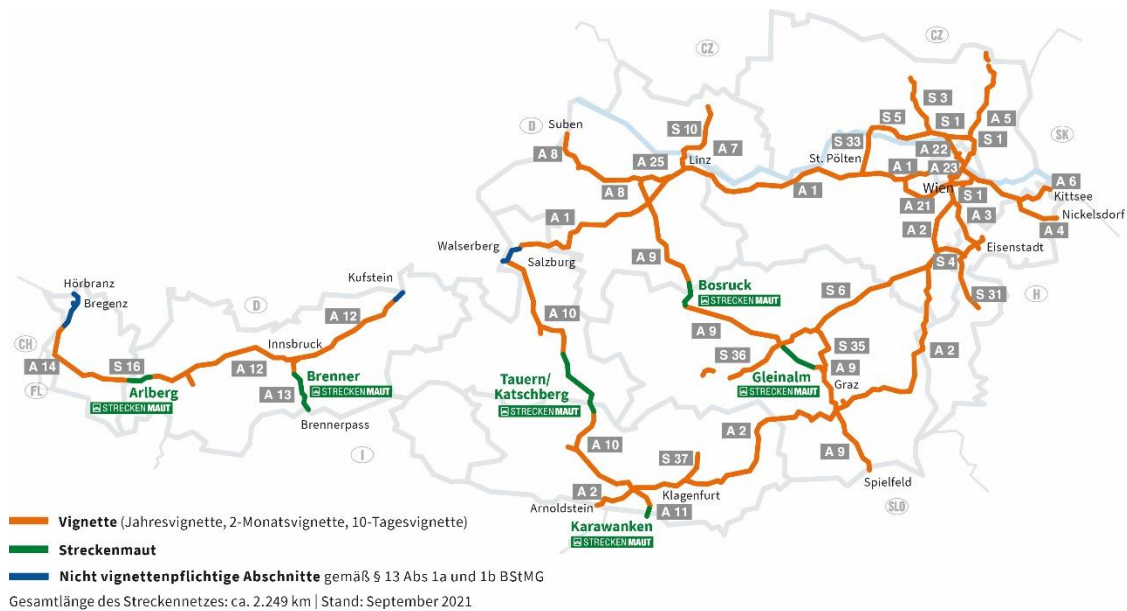

Figure 1

Toll roads in Vienna:



Figure 2

All extensions of the road network subject to tolls must be specified and published in Appendix 4 (toll rates per road section net). The time-related toll must be paid for these extensions as soon as they come into effect.

In accordance with section 13(1a) in conjunction with section 33(14) and (15) BStMG, the following sections of motorway and expressway are excluded from the mandatory time-related toll:

- the A 1 Westautobahn motorway between the state border at Walsberg and the Salzburg Nord junction
- the A 12 Inntalautobahn motorway between the state border near Kufstein and the Kufstein-Süd junction
- the A 14 Rheintal/Walgau motorway between the state border near Hörbranz and the Hohenems junction

The A 26 Linzer motorway will be subject to time-related toll payment only from the day after the opening of its connection to the A 7 Mühlkreis motorway junction Linz/Hummelhof for traffic.

In accordance with section 10(2) BStMG, the following sections of motorway and expressway are excluded from the mandatory time-related toll system (see Tolling Regulations Part A II):

- the section of the A 9 Pyhrn motorway between the Spital/Pyhrn and Ardning junctions and between the St. Michael intersection and the Übelbach junction;
- the section of the A 10 Tauern motorway between the Flachau and Rennweg junctions;
- the section of the A 11 Karawanken motorway between the St. Jakob im Rosental junction and the national border in the Karawanken tunnel;
- A 13 Brenner motorway
- the section of the S 16 Arlberg expressway between the St. Anton and Langen junctions.

In accordance with the Ordinance issued by the Federal Minister for Transport, Innovation, and Technology on the exemption of federal road sections from the toll obligation (Toll Section Exemption Ordinance 2010), the following sections of motorway or expressway are excluded from the mandatory time-related toll system:

- the section of the S 5 Stockerauer expressway between the Jettsdorf intersection (S 33) and the Krems junction (regional highway B 3, regional highway B 37).

1.3.2 Signing

Information signs on federal and regional highways leading to national border crossings for motor vehicle traffic notify road users of the obligation to have a valid vignette (see figures 3a and 3b). The mandatory vignette on toll roads is also indicated on additional information signs on approach roads (see figure 4).



Figure 3a*



Figure 3b*



Figure 4*

(*The 'GO' symbol refers to the toll for which vehicles with a maximum total weight of more than 3.5 t are liable, see Tolling Regulations Part B for details)

The exemption from the mandatory vignette according to section 13(1a) and (1b) BStMG is indicated on additional information signs at border crossings and approach roads within the sections concerned (see example of the A 14 in figure 5), respectively.



Figure 5*

1.3.3 Exceptions from vignette obligation

1.3.3.1 Permanent exemptions

The following vehicles are exempt from the mandatory vignette:

- Vehicles with visible blue headlights or warning lights in accordance with section 20(1)(4) and (5) of the Motor Traffic Act 1967 (hereinafter referred to as 'KFG' for short). In the case of motor vehicles pursuant to § 20 para. 5 KFG, an exemption from the toll obligation exists only for the duration of the use of the headlamp or warning light with blue light and if the conditions and requirements issued pursuant to § 20 para. 6 KFG are complied with during use. The return journey from an operation in which headlights or warning lights with blue light were used is also exempt from the vignette obligation.
- Vehicles with visible blue headlights or warning lights in accordance with section 20(5) of the KFG and registered in the name of non-profit institutions, the tasks of which are fulfilled mainly by voluntary workers. The regular use of motor vehicles for the purposes of these devices (or of a device mentioned in § 20 para. 1 Z 4 KFG) shall be deemed equivalent to a licence if headlamps or warning lights with blue light are visibly attached to the motor vehicles

in accordance with § 20 para. 5 KFG. The respective institution shall apply for the exemption from the vignette obligation to ASFINAG in writing by 30 September of each year for the following year and shall provide appropriate evidence that the conditions laid down in this provision are fulfilled and for which motor vehicles the exemption is applied for.

- Motor vehicles of fire brigade associations to which headlights or warning lights with blue light are visibly attached in accordance with § 20 para. 5 KFG.
- Army vehicles (section 2(1)(38) Motor Traffic Act 1967).
- Vehicles that are used within the scope of the agreement among the states party to the North Atlantic Treaty and the other states participating in the Partnership for Peace regarding the status of their forces ('PfP-SOFA'). If non-military vehicles are used for these trips, they shall provisionally be subject to the provisions of the time-related toll. The toll paid in the course of these trips will be refunded by ASFINAG free of charge. Applications for refunds must be submitted by the relevant state authorities once the trips have been completed. Refund applications must be accompanied by evidence that the toll was paid and submitted directly to ASFINAG Maut Service GmbH (see Appendix 7a).
- Motor vehicles used in the performance of peace-keeping operations within the framework of an international organisation, the Organisation for Security and Cooperation in Europe or the European Union pursuant to a decision taken under the common foreign and security policy. If non-military vehicles are used for these trips, they shall provisionally be subject to the provisions of the time-related toll. The toll paid in the course of these trips will be refunded by ASFINAG free of charge. The request for reimbursement must be submitted by the respective competent state authority directly to ASFINAG Maut Service GmbH (see information in point 1.13) after completion of the journeys, together with the relevant evidence.
- Vehicles belonging to the public security forces, tax authorities, prison services, and foreign security forces in accordance with section 2(3) of the Police Co-operation Act, as well as vehicles belonging to foreign customs and judicial authorities. Confiscated vehicles that use the road network subject to tolls and to which an official tax authority registration number has been attached are not liable for the toll.
- Vehicles belonging to foreign public emergency services, foreign fire brigades or foreign rescue services. Such motor vehicles shall be exempt from the obligation to pay tolls only if they are fitted with headlamps or warning lights emitting a blue light visibly on the outside and only for the duration of the use of the headlamp or warning light emitting a blue light. The return journey from an operation in which headlights or warning lights with blue light were used is also exempt from the vignette obligation.

Vehicles that have blue headlights or warning lights visibly attached to the exterior, but are not registered and therefore carry transfer license plates or other equivalent plates and that use the road network subject to tolls are not exempt from the toll obligation.

Autobahnen- und Schnellstraßen-Finanzierungs-Aktiengesellschaft must provide free vignettes for army vehicles (section 2 sub-paragraph 38 Motor Traffic Act 1967), vehicles belonging to the public security forces, tax authorities, and the prison services that have been allocated special licence plate numbers ('Deckkennzeichen') in accordance with section 48(1) Motor Traffic Act 1967.

In cases of doubt ASFINAG has the right to demand further proof for the above mentioned requirements for an exemption.

1.3.3.2 Temporary exceptions

1.3.3.2.1 *Urgent traffic restrictions*

In the event of an urgent traffic restriction within the meaning of section 44b(1) of the Road Traffic Act (StVO), BGBl. No. 159/1960 on a non-trunk road network, vehicles that are directed by officers of the road inspection authorities, road maintenance units, fire brigade, public breakdown service, or waste disposal companies to use sections of a motorway or expressway as part of the diversion route are not obliged to have a valid vignette on the motorway or expressway. Vehicles without a valid vignette must leave the motorway or expressway at the next possible exit.

1.3.3.2.2 *Exceptions for humanitarian aid transports*

In addition to the above provision, ASFINAG may in accordance with section 5(2) BStMG and depending on the circumstances, exempt vehicles with a maximum total weight of up to 3.5 t that are delivering humanitarian aid in the event of emergencies or disasters from paying the toll obligation.

In order to be able to carry out such a journey without the obligation to pay the toll (affixing a toll sticker as defined in point 2 or registration of the license plate number in the toll system as defined in point 3), the application for exemption in accordance with Appendix 3a (which can be found at www.asfinag.at) must be completed, duly signed and submitted by e-mail (info@asfinag.at) or by fax (+43 / 1 955 12 77) at least 24 hours before use of the road network subject to tolls. The applicant will receive confirmation. This confirmation must be carried in the vehicle for the duration of the trip that is exempt from the toll obligation and must be presented upon request as evidence of exemption approval. Toll exemptions for journeys within the context of humanitarian aid transports apply to both outward and return journeys.

This provision applies without exception only in the event of an incident within the meaning of § 5 para. 2 BStMG and the specific incident is announced in the tolling regulations at this point.

1.3.3.2.3 *Exceptions at the request of the Federal Ministry of the Interior (BM.I) in the context of state crisis and disaster control management or international disaster aid*

At the request of the Federal Ministry of the Interior (BM.I), trips carried out by motor vehicles with a maximum permissible total weight of up to 3.5 t within the framework of state crisis and disaster protection management or international disaster relief may be exempted from the payment of tolls on a case-by-case basis.

To enable such trips to be made without the obligation to pay the toll (affixing a toll sticker as defined in section 2 or registering the license plate number in the toll system as defined in section 3), the Federal Ministry of the Interior (BM.I) must notify ASFINAG of these trips, listing the license plate number of the motor vehicles concerned and announcing the expected route and the exemption period before using the road network subject to toll payment.

The written confirmation of the Federal Ministry of the Interior (BM.I) concerning the concrete exception to the toll duty during the toll-free trip must be carried in the affected motor vehicles and presented on request as proof of entitlement.

1.4 VIGNETTE PRICES

The vignette prices are set by decree of the Federal Minister for Climate Protection, Environment, Energy, Mobility, Innovation and Technology in agreement with the Federal Minister of Finance. The valid vignette prices are quoted in Appendix 1 and vary according to the type of vehicle and the duration of use. Prices include 20% VAT.

1.5 DURATION OF ENTITLEMENT OF USE

The validity period of the toll sticker and the digital vignette is the same. The validity period of a toll sticker can be visually verified, whereas the validity of a digital vignette can be checked (free of charge) by retrieving the vehicle's license plate number in the vignette registry.

1.5.1 Annual toll sticker

The annual toll sticker is valid for the year indicated on the toll sticker. Furthermore, it may be used from 01 December of the previous year to 31 January of the following year of the year designated on the toll sticker (see Appendix 1).

When using the digital annual vignette the validity period will be indicated, besides the query of the vignette registry, on the (latest valid) order confirmation, issued after registering the vehicle's licence plate number in the toll system.

1.5.2 Two-month vignette

The two-month vignette entitles the bearer to use the roads for two months, from the first day of validity. The first day of validity can be chosen within the validity period (for possible restrictions regarding the two-month digital vignette see section 3.2.1.1).

When using a two-month toll sticker the first day of validity will be marked by a hole in the appropriate starting day in accordance with the toll sticker samples (see Appendix 1). The hole will be punched by the seller at the toll sticker sales points.

In case of using a two-month digital vignette the validity period will be indicated, besides the query of the vignette registry, on the (latest valid) order confirmation, generated after registering the vehicle's license plate number in the toll system.

This toll sticker expires at the end of the day of the second month that corresponds to the date on which the toll sticker came into effect (= first day of validity) or, if no such date exists in that month, at the end of the last day of the second month (see Appendix 1).

The last possible first day of validity of a two-month vignette from the current calendar year is 30 November. Due to the two-month validity period, this two-month vignette may be used until 30 January of the following year. In case a two-month vignette should have its first day of validity in December of any calendar year, only a two-month vignette of the following calendar year can be purchased.

1.5.3 Ten-day vignette

The ten-day vignette entitles the holder to use the road for ten consecutive calendar days from the first day of validity. The first day of validity can be chosen within the validity period (for possible restrictions on the digital ten-day vignette, see in particular point 3.2.1.1).

When using a ten-day toll sticker the first day of validity will be marked by a hole in the appropriate starting day in accordance with the toll sticker samples (see Appendix 1). The hole will be punched by the seller at the toll sticker sales point.

In case of using a ten-day digital vignette the validity period will be indicated, besides the query of the vignette registry, on the (latest valid) order confirmation, generated after registering the vehicle's license plate number in the toll system.

The last day in a calendar year from which onwards the ten-day vignette is valid, is the 30th of November. On the basis of the ten-day period of validity, this ten-day vignette may only be used until 9 December of the same calendar year. In case a ten-day vignette has its first day of validity in December of any calendar year, only a ten-day vignette of the following calendar year can be purchased.

1.6 RELIEF MEASURES

1.6.1 Free vignettes for people with disabilities

Persons with disabilities ("persons entitled to benefits") are entitled to a free digital vignette under the conditions of § 13 BStMG in conjunction with the Insurance Tax Act of 1953 and the associated ordinance (ANB-V as amended).

For this purpose, the claimant must contact the local registration office responsible for the registration of the motor vehicle.

The examination of the eligibility conditions according to § 13 para. 2 of the BStMG is carried out by the municipal body of the insurer entitled to operate the motor vehicle liability insurance ("municipal body").

After successfully passing the eligibility requirements inspection, the municipal body shall arrange for the registration of the vehicle license plate of the exempted motor vehicle in the ASFINAG toll system. The vehicle of the claimant entitled to benefits remains exempted if the vehicle license plate is changed.

At the time of registration in the ASFINAG toll system, the entitled party will receive a free digital vignette.

A query of the vehicle license plate in the vignette registry (see point 1) provides information as to whether an exempted vehicle has a valid digital vignette and for what period it is valid. The digital vignette is displayed in the vignette registry in the respective year as a digital annual vignette (see item 1.5.1 "Duration of the entitlement to use").

1.6.2 Right to reimbursement of vignettes issued for disabled persons

Pursuant to § 13 para. 7 of the BStMG, ASFINAG shall, upon request, reimburse to someone who is entitled to benefits the price of one or several annual vignettes which he or she has demonstrably acquired for the motor vehicle registered in his or her name from the calendar year in which one of the aforementioned entries in the claimant's disabled person's pass was valid.

The price of an annual vignette shall be refunded for each person entitled to benefits for each vignette year.

To apply for a refund, the claimant must submit the following documents to ASFINAG Maut Service GmbH (see information under item 1.13):

- Copy of the vehicle registration certificate of the disabled pass holder
- Proof of residence or usual abode in Germany
- Copy of the disabled person's pass in which the unreasonableness of using public transport or blindness is documented
- Invoice for the previously purchased annual toll sticker or its allonge or the product ID of the digital annual vignette.

In cases of doubt, ASFINAG shall be entitled to demand further evidence (e.g. confirmation from the Federal Office for Social Affairs and Disability that no vignette has been provided free of charge).

1.7 OBLIGATIONS

Before using the road network subject to tolls with a vehicle that is liable for the toll, every driver has to make sure that, for the period of the intended use of the road network subject to tolls, the time-related toll has properly been paid for (in advance). This includes checking if the toll has properly been paid by using the correct type of vignette, according to the vehicle type.

In case of using a toll sticker to pay the toll, the bearer has to visually check if the toll sticker is attached in the correct location, it is attached properly (if carrying an unattached toll sticker is not explicitly permitted, see section 2.2.2), and that it is "intact" as well as visible and verifiable.

In case of using a digital vignette, the vehicle registration number in the vignette registry (see section 1) must be queried immediately before the road network subject to tolls is used to determine

whether a vehicle has a valid digital vignette and for which time period it is valid (or they are valid if the vehicle has several digital vignettes).

Furthermore, every vehicle driver has to – according to section 102(2) KFG – make sure that the official license plate number of the vehicle that is liable for toll, is completely and permanently visible during the journey and has not been covered by dirt or snow, respectively damaged deformed in such a way that it is illegible.

If the time-related toll has not been properly paid in advance, the driver must refrain from intending to use the road network subject to tolls. Otherwise, the offence of toll evasion as defined in point 1.9 shall be deemed to have occurred.

1.8 MONITORING COMPLIANCE WITH THE VIGNETTE OBLIGATION

1.8.1 Inspection by road inspection authorities and toll enforcement officers

Compliance with payment of the time-dependent toll is monitored by the toll enforcement officers in accordance with §§ 17ff BStMG. The toll enforcement officers are organs of public supervision. They are appointed and sworn in in accordance with the provisions of § 17 (2) BStMG. In the performance of their duties the toll enforcement officers must carry with them the identification document described below and present it to the parties concerned upon request.

The ID card of the toll enforcement officers, which confirms their official status, is the size of a credit card, is printed on both sides and contains the following information in particular: the photograph, name and service number of the toll enforcement officer (see Figure 6).



Figure 6

The toll enforcement officers' vehicles are public security force enforcement vehicles that comply with section 20(1)(4) lit.a of the Motor Vehicle Act 1967. These vehicles are silver-grey operational vehicles that are equipped with flashing blue lights and a siren. Furthermore, they are marked with the following words: "ASFINAG", "toll enforcement" and "ASFINAG service and toll enforcement unit" (see Figure 7).



Figure 7

For the purposes of checking correct payment of the toll as well as the time-related toll and section toll, the toll enforcement officers are empowered, among other things, to request drivers to stop by using clearly visible or audible signs, to stop them, to check the affixing of the toll sticker or the registration of the license plate in the toll system, to establish the identity of the driver and of the holder of the registration certificate, the motor vehicle (in particular the vehicle registration certificate), – in the case of journeys with test or transfer license plates within the meaning of point 1.2 – to check evidence of the vehicle's tare weight (in particular a copy of the type certificate), and to ask drivers to pay any substitute toll due.



Figure 8

Furthermore, the toll enforcement officers for the purposes of monitoring correct payment of the toll and performance of the traffic recording are authorised to divert motor vehicles using automatic traffic diversion equipment to the toll inspection areas, currently A1 Eberstalzell, A1 Haag, A1 Walserberg, A2 Arnoldstein, A2 Arnwiesen, A2 Haimburg, A2 Ilztal, A6 Kittsee, A4 Bruck/Leitha, A4 Nickelsdorf, A4 Gols, A4 Zurndorf, A5 Schrick, A8 Kematen, A8 Suben, A9 Schoberpaß, A9 Straß, A10 Hoher Göll, A10 Kellerberg, A11 Rosegg, A11 Karawankentunnel, A12 inspection bay Roppener Tunnel Ostportal, A12 inspection bay Zirl Ost, A12 junction Wörgl-Ost, A14 Hörbranz, A14 Nüziders, S4 Pöttsching, S3 Göllersdorf, S16 "Kettenanlegeplatz" (a place where drivers can attach snow chains to the tires) Bings, S31 Hirm Nord, S31 Hirm Süd and S37 Maria Saal.

Additionally, toll enforcement officers may also monitor the correct payment of tolls and conduct traffic surveys at border crossings and junctions.

If the substitute toll is not paid and if criminal prosecution or enforcement of the penalty appears to be impossible or significantly impeded, toll enforcement officers are authorized in accordance with § 27 BStMG to collect a provisional security or, until the stipulated provisional security is paid, to order the interruption of the journey in accordance with § 28 BStMG and to prevent its continuation

using suitable precautions (confiscation of the vehicle keys and documents, attachment of technical barriers to the vehicle to prevent it being moved, parking at a suitable location, etc.).

1.8.1.1 Inspection of the moving traffic (on inspection areas and junctions)

Whether the toll has been paid or not will be examined by the toll enforcement officers by a visual inspection (toll sticker) as well as by the help of technical devices (digital vignette) on the spot.

For that particular purpose a camera will be placed at the roadside (on the access or exit of a motorway or expressway on which toll is being levied or on traffic inspection areas) and adjusted towards the driving lane. The license plate numbers of all passing vehicles will be captured to verify whether they have a valid digital vignette or not.

The result of this examination will be indicated to the toll enforcement officer via a mobile display device. Subsequently, the toll enforcement officer may visually verify if the vehicle has a valid toll sticker properly attached to the vehicle.

1.8.1.2 Inspection of the stationary traffic

Besides the inspection of the moving traffic, there are also mobile inspections of the stationary traffic (e.g. on resting areas). The toll enforcement officer visually examines whether a toll sticker has been attached properly onto the vehicle. If this is not the case, the toll enforcement officer will verify if a digital vignette has been acquired for the vehicle.

1.8.2 Automatic vignette monitoring

The automatic monitoring of vignettes (AVK) is carried out in accordance with the requirements of the BStMG and is registered with the Data Processing Register. It is a mobile electronic system that selectively monitors whether tolls have been correctly paid. The AVK is used at constantly changing locations across Austria for a limited period at each location.

The AVK uses special software to check the windscreens of passing vehicles concerning attached toll stickers respectively the passing vehicle's license plate numbers, to examine whether the license plate number has been registered in the toll system. The system is capable of identifying the validity of toll stickers and only stores images of vehicles which are suspected of not having paid the time-related toll properly (suspicion of toll evasion in accordance with section 20 BStMG, see also section 10 below). Cases not considered suspicious will not be stored for statistical or other purposes once the monitoring process is complete.

The suspicious case stored in relation to the automatic monitoring will subsequently be checked and verified by caseworkers of ASFINAG Maut Service GmbH. Manual processing involves performing several checks. If the suspicious case is confirmed, proceedings to ensure payment of a substitute toll will be initiated.

1.9 TOLL EVASION

1.9.1 Penalties for toll evasion

It is prohibited to drive a vehicle that is liable for the toll within the meaning of Tolling Regulations on the road network subject to tolls without a valid toll sticker that has either been properly attached to the vehicle or properly carried in the vehicle in accordance with section 2.2.2 of Tolling Regulations Part A I. In accordance with section 20(1) BStMG, drivers who violate this prohibition are in breach of an administrative rule and may be fined between **€300.00** and **€3,000.00** by the local district administrative authorities.

1.9.2 Non-imposition of a penalty

A penalty will not be imposed if a substitute toll - as described below - is paid. Any substitute toll duly paid in accordance with § 19 BStMG cannot be reclaimed (§ 20 para. 6 BStMG).

1.9.3 Substitute toll

1.9.3.1 Method of payment

The substitute toll may not be paid in instalments. If instalments are received, they will be credited to the payer's account minus a processing fee of €15.00 (including 20% VAT). This also applies to late payments, payments without stating the correct identification number or invoice number, as well as payments to an account other than the one disclosed on the copy of the request for payment of a substitute toll or an information letter pursuant to section 30b para. 1 BStMG. In the event of overpayment by less than €5.00, no money will be credited to the payer's account (otherwise the entire amount will be credited to the payer's account).

1.9.3.1.1 Request by toll enforcement officers

Toll enforcement officers are authorized to verbally request the motor vehicle driver (if necessary also as representative of the license holder in accordance with § 19 para. 5 BStMG) to pay a substitute toll. The substitute toll shall be paid immediately upon request by the toll enforcement officer in cash or by the payment method specified in Appendix 2 of the Toll Code. The vehicle driver shall be issued with a confirmation of the payment made.

1.9.3.1.2 Discovery of a violation in the absence of the driver

If a violation is discovered by toll enforcement officers during the course of their work without the driver being apprehended in person (e.g. because the driver is not at the vehicle), a written request to pay the substitute toll may be left at the vehicle. In addition to the amount of the substitute toll to be paid, the written request shall contain, among other things, an identification number or an invoice number and the claimant's bank details.

The substitute toll shall be paid to the account specified in the request for payment, indicating the identification number or invoice number specified in the request. The request for payment of the

substitute toll is complied with if it is credited to the specified account within two weeks of the deposit and the transfer order contains the correct, complete and automatically readable identification number (or invoice number).

1.9.3.1.3 *Retroactive summons procedure*

If a violation is discovered by means of automatic monitoring of vignettes without the driver being apprehended in person, the/a registration certificate holder may receive a written request to pay the substitute toll. In cross-border procedures, the request for payment of the substitute toll is made in the form of an information letter in accordance with section 30b para. 1 of the BStMG, which is listed as a template in Appendix 8 to the tolling regulations.

In addition to the amount of the substitute toll to be paid, the written request shall contain, among other things, an identification number or an invoice number and the claimant's bank details.

The substitute toll must be transferred to the account specified in the request for payment or the information letter in accordance with section 30b para. 1 BStMG, stating the identification number or invoice number specified in the request. The request for payment of the substitute toll shall be complied with if it is credited to the specified account within four weeks of the issuance of the request or the information letter pursuant to section 30b para. 1 BStMG and the transfer order contains the computer-readable, complete and correct identification number (or invoice number).

1.9.3.2 Substitute toll rate

The substitute toll rates (including 20% VAT) for non-payment of the time-related toll are given below:

Vehicle category	Substitute toll rate
A (i.e. single-track vehicles)	€ 65.00
B (i.e. twin-track vehicles an MPW of up to 3.5 t)	€ 120.00

If a toll sticker has not been attached properly to the vehicle (see section 2.2.) and has been manipulated either by chemical or technical means in such a way that the toll sticker is prevented from self-destruction upon removal or multiple use can not be excluded, the price of the substitute toll will be doubled for each category (see table above).

If the change (see section 3.6) has been omitted prior to the use of the road network subject to tolls, with the vehicle that is liable for toll, the following applies:

If it is established that the toll has not been properly paid and the driver of the motor vehicle is requested in writing by toll enforcement officers or the holder of the registration certificate is requested by ASFINAG to pay the substitute toll, the driver of the motor vehicle/holder of the registration certificate may, after receiving the request to pay a substitute toll or an information

letter in accordance with section 30b para. 1 BStMG, contact the ASFINAG Service Center, which will carry out the re-registration on the new license plate number to be registered upon presentation of suitable evidence, if the prerequisites for a re-registration of the digital annual vignette according to point 3.6 are met.

In this case, with the proper payment of the substitute toll, the time-related toll for the license plate number, which has been newly assigned to the holder of the registration certificate, will be paid retroactively for the period between the date of the first breach of an administrative rule with the newly assigned license plate number and the date of change. The amount of EUR 18.00 for the change (see section 3.6) is not payable in this case and/or will be reimbursed.

If the road network subject to tolls has been used before the start of validity of the digital annual vignette, the following applies:

If it is established that the toll has not been properly paid and the driver of the motor vehicle is requested in writing to pay the substitute toll by toll supervisory officers or the holder of the registration certificate by ASFINAG, the driver of the motor vehicle/holder of the registration certificate may, after receiving the request for payment of a substitute toll or an information letter in accordance with section 30b para. 1 BStMG, contact the ASFINAG Service Center and invoke the fact that the road network subject to tolls with the license plate number concerned was used in the period between the purchase of the digital annual vignette and the start of its validity.

In this case the time-related toll for this time period will be paid retroactively with the proper payment of the substitute toll.

If the use of the road network subject to tolls with a motor vehicle with an obligation to pay tolls without a valid toll sticker is detected several times within 30 days, ASFINAG will issue requests for payment of a substitute toll or send information letters in accordance with section 30b para. 1 BStMG for a maximum of three cases of toll evasion. No substitute toll is payable for any additional toll evasion cases and these cases will not be reported to the local district administrative authorities.

1.9.3.3 Continued journey

Payment of the substitute toll authorises the driver of the vehicle to use the toll (vignette) road network on the day the driver was apprehended by a toll enforcement officer, on the day on which an enforcement officer has left a written request for payment of the substitute toll on their vehicle, on the day on which the breach of an administrative rule has been determined by automatic monitoring and on the following calendar day.

Either the receipt issued after the driver was apprehended or the payment slip attached to the written request to pay the substitute toll are considered to be proof of payment of the substitute toll. In the event of non-compliance, the offence of toll evasion shall be committed. Drivers who refuse to pay the toll after being apprehended are obliged to leave the toll road immediately at the next possible exit.

Upon leaving the vehicle, the driver must ensure that the receipt or the payment slip is placed inside the windscreen in such a way that the entitlement of use (especially the location, date, and time of issue and the vehicle's license plate number) can easily be seen and inspected from outside the vehicle.

Failure to comply with this provision constitutes a toll evasion offence.

1.9.3.4 Payment of the substitute toll

Substitute tolls must be paid in euros. The information on which methods and means of payment are permitted for the payment of the substitute toll to toll supervisory bodies is regulated in Appendix 2 and is available on the internet at www.asfinag.at or from customer service (see information under point 1.13).

1.10 VIOLATION OF THE OBLIGATION TO STOP

Motor vehicle drivers who, contrary to § 18 para. 2 BStMG, do not comply with a request to stop a body mentioned in point 1.8.1, are committing an administrative offence pursuant to § 21 BStMG and are liable to fines of up to EUR 3,000.00.

1.11 DATA PROTECTION AND DATA SECURITY

ASFINAG is entitled pursuant to § 16a BStMG to process the personal data required for toll collection, toll collection and the prosecution of toll evasion with the aid of automation. Furthermore, ASFINAG is also entitled to process personal data which is required for the vignette registry (see section 1) in accordance with section 16 BStMG.

To verify if the toll has been paid properly and to trace toll evasion, in accordance with section 19a BStMG, ASFINAG is entitled to use technical equipment. For the description of how the technical equipment is working see section 1.8.1 and 1.8.2. The image data and the license plate number and control data obtained from it may be processed for the purposes of collecting the toll, requesting payment of a substitute toll or the information letter pursuant to section 30b para. 1 BStMG and prosecuting toll evasion.

More detailed explanations of the data protection principles and information on the rights of data subjects are available on the internet at www.asfinag.at.

1.12 JURISDICTION AND APPLICABLE LAW

The exclusive place of jurisdiction for all claims against ASFINAG under civil law arising out of these Tolling Regulations and/or the use of the road network subject to tolls shall be the court that has jurisdiction as regards such matters for the first district in Vienna. Only Austrian law applies, excluding the conflict of laws rules of private international law.

1.13 RESPONSIBILITY AND CUSTOMER SERVICE (ASFINAG Service Center)

All queries or applications for refunds should be addressed to ASFINAG Maut Service GmbH:

ASFINAG Maut Service GmbH
Alpenstraße 99
A-5020 Salzburg, Austria
Tel.: 0800 400 12 400 (free of charge from Austria and Germany)
Tel.: +43 (1) 95 51 266 (not free of charge when calling from all other countries)
Fax: +43 (1) 95 51 277
E-Mail: info@asfinag.at / <http://www.asfinag.at>

2 FURTHER REGULATIONS WHEN USING A TOLL STICKER

In addition to the general regulations the following regulations apply in case a toll sticker is used.

2.1 SALE OR DISTRIBUTION OF THE TOLL STICKER

Toll stickers can be purchased at points of sale marked with the toll sticker symbol (see Appendix 1).

The price of purchased toll stickers cannot be refunded or replaced.

2.2 ATTACHING THE TOLL STICKER

2.2.1 Where and how to attach the toll sticker

Before using the road network subject to tolls, a valid toll sticker, which has to be appropriate to the respective vehicle category, must be properly attached to every vehicle that is liable for the toll using the original toll sticker adhesive strip (taking into account section 2.2.2 of the Tolling Regulations Part A I). Any other method of attachment (e.g. using [additional] adhesive strips, any other method of fixation, or covering the toll sticker with an additional protective film) is not permissible, nullifies evidence that the toll has been properly paid, and can constitute a toll evasion offence (see section 1.9). Ten-day toll stickers and two-month toll stickers are only valid if they have been validated by correctly and completely punching holes in the appropriate calendar day and month.

The adhesive vignette for multi-lane motor vehicles must - after it has been completely detached from the carrier film - be stuck undamaged and directly onto the inside of the windscreen in such a way that it is easily visible and controllable from the front outside (e.g. no sticking behind a dark tinted strip, no sticking in the case of panorama windows to parts of the windscreen which are curved backwards, no sticking to the side window). The non-observance of these toll sticker attachment provisions (e.g. if the toll sticker is not completely removed from the backing paper or if the toll sticker is not completely attached to the windscreen), can constitute a toll evasion offence (see section 1.9). Drivers are advised to observe the recommendations on how to attach the toll

sticker printed on the back of the toll sticker. On a motorcycle, toll stickers must be attached visibly and verifiable on a part of the motorcycle that is either difficult or impossible to remove.

In the interest of road safety and in order to ensure effective, user-friendly monitoring of time-related toll payment, a maximum of one other toll sticker should, if possible, be attached to the vehicle in addition to the valid toll sticker.

The removal and reattachment of an attached, valid toll sticker; the repeated use of the toll sticker, with the exception of the repeated use that is expressly permitted by these Tolling Regulations; or a chemical or technical manipulation of the original toll sticker adhesive strip in such a way that the toll sticker is prevented from self-destructing upon removal, is impermissible and can constitute a toll evasion offence.

2.2.2 Permissibility of carrying an unattached toll sticker in the vehicle

Drivers of approved vehicle models without windscreens are permitted to carry an unattached toll sticker in the vehicle. The same applies if windscreens may not be brought into contact with the adhesive vignette sticker due to a technical certificate issued by the manufacturer, provided that a vehicle-related release letter from ASFINAG Maut Service GmbH (see information under item 1.13) is carried along in the original.

In the case of vehicles that carry transfer license plates, drivers are permitted to carry an unattached, properly stamped two-month toll sticker in the vehicle instead of directly attaching the toll sticker to the vehicle (please refer to section 2).

Before leaving a parked vehicle (e.g. at service areas on the road network subject to tolls) the driver must ensure that the toll sticker is clearly visible and verifiable from outside the vehicle. Failure to comply with this provision constitutes a toll evasion offence (see section 1.9).

2.3 TOLL STICKER REPLACEMENT

In the event that the windscreen on which the adhesive annual toll sticker is affixed is destroyed and replaced, ASFINAG Maut Service GmbH (see item 1.13) will issue a replacement toll sticker free of charge, provided that no claim is made against third parties. The following evidence must be presented when making use of the services:

- a copy of the vehicle registration certificate
- a copy of the invoice for the replaced wind screen issued by the garage that carried out the repairs (in the case of company cars, the name of the driver must also be given);
- the detached toll sticker together with the lower section (allonge) of the toll sticker;
- a toll sticker replacement form (filled out and signed).

If a vehicle to which an annual toll sticker is attached is damaged to such an extent as a result of an accident or force majeure that the vehicle is no longer roadworthy (i.e. the vehicle is a technical write-off), the owner of the annual toll sticker is entitled to apply for a free replacement toll sticker from ASFINAG Maut Service GmbH as long as there are no claims against third parties.

The following evidence must be presented when making use of the services:

- the original removed annual toll sticker or a sufficient part of the remaining toll sticker including the lower section (toll sticker tab and/or backing paper);

- confirmation from a garage or automobile club that the vehicle is a technical write-off or confirmation that it has been scrapped or handed over to a third party for scrapping.
- confirmation from the vehicle registration unit that the vehicle has been removed from the register;
- brief description of the events that occurred.

In cases where the toll sticker has been rendered invalid or destroyed in circumstances that fall within the sphere of responsibility of the toll sticker producer, ASFINAG Maut Service GmbH (see information in section 1.13) or its authorised agents shall provide a replacement of the toll sticker free of charge.

In cases of doubt, ASFINAG is entitled to request photographic evidence of the vehicle in question.

If the applicant wishes to register their license plate number in the toll system (digital vignette) instead of a replacement of the toll sticker, they should request that on the toll sticker replacement form and attach the vehicle registration certificate.

More details and the toll sticker replacement form are available on the Internet at www.asfinag.at (please refer also to the information in section 1.13). It is impermissible for a driver to use toll roads until such time as the replacement toll sticker has been received.

No replacements are provided for toll stickers that are destroyed in other circumstances (e.g. the removal of a toll sticker that has already been attached).

3 FURTHER REGULATIONS WHEN USING A DIGITAL VIGNETTE

3.1 AVAILABILITY OF THE DIGITAL VIGNETTE

Alternatively to the use of a toll sticker, the time-related toll can also be paid since 1 December 2017 by registering the vehicle's license plate number (digital vignette) in ASFINAG's vignette registry.

From the time of validity of the digital vignette (see in detail below), the toll for the indicated license plate number is thus properly paid and entitles the digital vignette to use federal roads in accordance with sections 1 para. 1 and 11 para. 1 Federal Road Tolls Act.

3.2 OBTAINING THE DIGITAL VIGNETTE

The following distribution channels are provided to register the vehicle's license plate (obtaining the digital vignette) in ASFINAG's toll system.

3.2.1 Obtaining the digital vignette in the Webshop and with the ASFINAG app

The digital vignette can be obtained in the Webshop or with the ASFINAG app from within Austria, the European Union as well as in the EEA states and Switzerland.

3.2.1.1 Start of validity

If the digital vignette is obtained by means of distance selling, i.e. in the Webshop or in the ASFINAG app, the first day of validity is generally no earlier than the 18th day after obtainment. As an example:

On 15 January, a digital vignette is obtained in the ASFINAG Webshop. The first day of validity is therefore 2 February at the earliest and the right to use the motorways and expressways only exists from this day onwards.

A different, later date for the first day of validity (in the above example, 5 April) can be selected manually when purchasing digital two-month and ten-day vignettes. It is only possible to choose dates for which the vignette prices are already set and implemented at the time of purchase (see section 1.4).

The right to use motorways and expressways is valid from the selected first day of validity, but at the earliest from the 18th day after obtainment.

The duration of entitlement of use is regulated in section 1.5.

With regard to the acquisition of the digital subscription service and the associated specific features please see 3.2.5.2. and 3.2.6 on the digital annual vignette.

3.2.1.2 Required minimum information

To obtain a digital vignette in the Webshop or with the ASFINAG app, the following information has to be provided:

- The vehicle's license plate number that shall be registered in the toll system as well as the state of registration of the particular vehicle
- Data relevant for the cashless purchase (e.g. data of the credit card, etc.)
- A valid e-mail address (for the purpose of sending an order confirmation, the receipt, as well as the terms of use)

The order confirmation must be checked for the correctness of the data (especially with regard to the registered license plate number and the validity period of the digital vignette).

For later changes of the digital vignette in the Webshop or via the ASFINAG app under "My Account" (see section 3.6 and 3.2.4) the product-ID is needed, which serves also as an identification and is displayed on the order confirmation. The order confirmation should therefore be kept for the duration of the validity of the digital vignette.

3.2.2 Purchase of the digital vignette at a vending machine

The digital vignette can also be obtained at vending machines. They are freely accessible. Further information about the location of those vending machines is available on www.asfinag.at.

3.2.2.1 Start of validity

If the digital vignette is obtained at a vending machine, it is immediately valid and the permission to use the motorways and expressways is granted right away, with the exception of digital annual vignettes which, in accordance with section 1.5, entitle the bearer to use the motorways and expressways only in the following year.

A different, later date for the first day of validity can be selected when purchasing digital two-month and ten-day vignettes. Please refer to points 1.5 and 3.2.1. for the duration of the user authorization and the last possible first day of validity.

The right to use the motorways and expressways exists from the selected first day of validity.

The duration of entitlement of use is regulated in section 1.5.

3.2.2.2 Required minimum information

To purchase a digital vignette at a vending machine the license plate number, which should be registered in the toll system of ASFINAG, as well as the state of registration of the particular license plate and the type of vehicle, have to be provided.

A confirmation about the registration of the license plate number in the toll system of ASFINAG (order confirmation) as well as the receipt will be printed at the vending machine. The order confirmation must be checked for the correctness of the data (especially with regard to the registered license plate number and the validity period of the digital vignette).

For subsequent changes and re-registrations of the digital vignette in the personal user account (see points 3.6 and 3.2.5), the product ID stated on the order confirmation is required as identification. The order confirmation should therefore be kept for the duration of the validity of the digital vignette.

3.2.3 Obtaining the digital vignette from points of sale

The digital vignette can also be obtained from selected points of sale. Further information on the points of sale is available on the Internet at www.asfinag.at.

3.2.3.1 Start of validity

If a digital vignette is purchased from a point of sale, it is valid immediately and entitles the holder to use the motorways and expressways immediately after purchase, with the exception of digital annual vignettes which, in accordance with section 1.5, entitle the bearer to use the motorways and expressways only in the following year.

A different, later date for the first day of validity can be selected when purchasing digital two-month and ten-day vignettes. Please refer to points 1.5 and 3.2.1. for the duration of the user authorization and the last possible first day of validity.

The right to use the motorways and expressways exists from the selected first day of validity.

3.2.3.2 Required minimum information

In order to obtain a digital vignette at a point of sale, the vehicle license plate number to be registered in the ASFINAG toll system, including the country of registration of the vehicle license plate number, as well as the type of vehicle must be indicated and the corresponding registration certificate must be inspected at the request of the point of sale to check the plausibility of the information.

The confirmation of registration of the license plate number in ASFINAG's toll system (order confirmation) and the invoice will be printed out at the point of sale. The customer must check the order confirmation to ensure that the data entered there (in particular the registered license plate number and the validity period of the digital vignette) are entered correctly. Any need for correction must be reported immediately at the point of sale.

For subsequent changes and re-registrations of the digital vignette in the personal user account (see points 3.6 and 3.2.5), the product ID stated on the order confirmation is required as identification. The order confirmation should therefore be kept for the duration of the validity of the digital vignette.

3.2.4 Means of payment

The payment of the digital vignette in the Webshop, the ASFINAG app and at vending machines has to be made exclusively in EUROS. Further information on which methods of payment or means of payment are accepted in the Webshop, the ASFINAG app and at vending machines, is available in Appendix 2, on www.asfinag.at and at the customer service (see the information in section 1.13) respectively.

The means of payment accepted at a point of sale may vary depending on the point of sale and should be enquired from them.

3.2.5 Further Services

3.2.5.1 General services

In the Webshop as well as in the ASFINAG app, it is possible to create a personal user account ("My Account") at any time (i.e. even after completion of the purchase process) by entering access data.

The following services are provided after creating a personal user account and logging in to the Webshop respectively the ASFINAG app:

- administration of personal data
- administration of vehicles' license plate numbers
- allocation of digital vignettes that have already been obtained to the personal user account according to the product-ID
- administration of digital vignettes that have already been obtained
- reprints of receipts
- Acquisition and management of a digital subscription (exclusively in the Webshop, not on the ASFINAG app)

3.2.5.2 Digital subscription in the personal user account ("My Account")

A digital subscription – a subscription for an indefinite period for acquiring the digital annual vignette in subsequent years – can be taken out, managed (for example keeping credit card details up to date) and cancelled in the Webshop.

The following applies for this:

- Validity: The regulations regarding the commencement of the validity of the digital annual vignette in 3.2.1.1 for consumers and in 3.4 for entrepreneurs apply accordingly to the initial purchase of a digital annual vignette and the acquisition of the digital subscription (= initial acquisition).
- Right of withdrawal policy: On initial acquisition of the digital subscription, consumers are entitled to withdraw in accordance with 3.3. This right of withdrawal no longer applies, however, with regard to subsequent payments as part of the digital subscription.
- Information for customers: In order to obtain the digital subscription, providing an e-mail address is required. At least 20 days before payment is collected, the customer receives information, particularly on the date of the upcoming collection of payment (collection of the acquisition price of the annual vignette), the amount to be collected and the last possible date by which cancellation of the digital subscription for subsequent payments is possible. This e-mail address is also used to inform the customer whether collection of payment was successful.
 - *Successful transaction*: Following successful collection and thus the acquisition of a digital annual vignette, the customer is informed via the e-mail address specified by the customer and sent the order confirmation and invoice for the transaction. In this case the digital annual vignette is valid as from collection of the acquisition price.
 - *Unsuccessful transaction*: The customer is also informed about this via an e-mail to the e-mail address specified by them. If collection is not possible (for example because the credit card specified is no longer valid), this counts as timely cancellation of the digital subscription. In this case, the customer must ensure that

the toll is duly paid at the time that the roads for which a vignette is required are used. All sales channels for both the toll sticker and the digital vignette are available to the customer for this.

- Cancellation of the digital subscription: Cancellation of the digital subscription can only be made in the personal user account ("My Account") without giving reasons.
- Means of payment: The possible means of payment for the digital subscription are listed in Appendix 2.
- Data required: In addition to the minimum information required to obtain a digital vignette (see 3.2.1.2), it is necessary to create a personal user account (My Account) to obtain the digital subscription. Furthermore, the payment details for collecting subsequent payments must be entered and kept up to date.

3.2.6 Terms of use

Further information on obtaining the digital vignette in the Webshop and via the ASFINAG app, obtaining the digital subscription, the therefore required details and steps as well as on additional services, is available in the terms of use, which can be retrieved on www.asfinag.at.

In addition, customers may, upon request, inspect the current tolling regulations and the data privacy policy (www.asfinag.at/privacy) at points of sale at any time.

3.3 RIGHT OF WITHDRAWAL

If the digital vignette has been purchased by means of distance communication (Webshop or ASFINAG app), the customer can withdraw from the purchase without stating any particular reason, within 14 calendar days from the day on which the digital vignette has been bought.

In order to exercise the right of withdrawal, ASFINAG must be informed of the decision to withdraw from the subscription by means of a clear statement. The withdrawal period shall be respected when the withdrawal notice is sent within the deadline.

There is no right of withdrawal in the event of purchase at a point of sale or at a vending machine. This also applies if a digital annual vignette has been obtained as a subsequent purchase via a digital subscription.

More detailed information on the declaration of withdrawal as well as on the refund of payments made is available in the terms of use on the internet at www.asfinag.at.

3.4 SPECIFICS FOR ENTREPRENEURS CONCERNING THE PURCHASE OF A DIGITAL VIGNETTE

If an entrepreneur purchases a digital vignette or the digital subscription within their work as an entrepreneur, the following regulations apply:

When obtaining a digital vignette and/or a digital subscription in the Webshop or with the ASFINAG app, an entrepreneur needs to confirm their entrepreneurial status as well as the purchase of the digital vignette and/or the digital subscription within their work as an entrepreneur. In this case there is no right of withdrawal and the day of purchase of the digital vignette can be chosen as the first day of validity.

In addition to the minimum details for the purchase of the digital vignette mentioned in section 3.2.1.2, the invoice recipient's details can respectively must be provided if the amount succeeds EUR 400 (gross).

3.5 POSSIBLE CHANGES BEFORE THE BEGINNING OF VALIDITY

If the validity of a digital vignette has not started yet, the vehicle's license plate number and the state of registration registered in the toll system can be changed. Moreover, in case of two-month and ten-day vignettes the first day of validity can only be changed under the following conditions:

- If the digital vignette has been obtained in the webshop or in the app, the first day of validity may not be before the 18th day, midnight, following the obtainment.

Example: A digital ten-day vignette was obtained in the webshop on 15 January. 15 January. The earliest possible start of validity is therefore 2 February, midnight.

- The first day of validity may not be changed to a day in the past – at the time of the change

Example: A digital ten-day vignette with validity beginning on 1 April was obtained. If the first day of validity of this vignette is changed on 25 March, please note that the new start of validity must not be postponed to 24 March or earlier (i.e. into the past).

- Basically, the beginning of validity can be changed to the day on which the change is made, whereby the permission to use the road network subject to tolls only begins at the time of change.

Example: If today at 14:07 the beginning of validity of a digital vignette is changed to today, the road network subject to tolls can be used only from 14:07. The use of the road network subject to tolls before that time, referring to that vignette, is prohibited and constitutes toll evasion.

- The first day of validity can only be changed between 1 December of the current year and 30 November of the following year (for details see points 1.5.2 and 1.5.3).

Example:

Possible: Postponement from 1 April to 1 October of the same calendar year.

Not possible: Postponement from 1 October to 10 December of the same year or from 1 October to 1 February of the following calendar year. It is also not possible to postpone from 10 December to 15 November of the same calendar year.

If the digital vignette has already been purchased, the following changes cannot be made:

- Change of the period of validity. This means that
 - a ten-day vignette cannot be changed to a two-month or annual vignette;
 - a two-month vignette cannot be changed to a ten-day or annual vignette;
 - an annual vignette cannot be changed to a ten-day or two-month vignette.
- Change of a digital vignette for a single-track vehicle to one for a two-track vehicle and vice versa.
- Change from a digital vignette to a toll sticker

Changes defined as permissible above can be made under the following conditions:

- In the Webshop and with the ASFINAG app (after the registration and login) in the personal user account (see section 3.2.4)
- At the customer service, toll stations and the point of sale where the digital vignette was purchased. The prerequisite is the presentation of the order confirmation or product ID, a copy of the registration certificate of the motor vehicle whose license plate number is currently registered, and – if the license plate number is changed – the registration certificate of the motor vehicle whose license plate number is to be registered.

In case of doubt, ASFINAG or the point of sale shall be entitled to demand further evidence.

3.6 RE-REGISTRATION FROM THE BEGINNING OF VALIDITY

After the beginning of validity only digital annual vignettes can be changed.

Thereby, a change of the vehicle's registered license plate number to a newly assigned license plate number of the same holder of the registration certificate can only be requested in the following cases:

- The holder of the registration certificate changes their place of residence and receives, due to the therefore necessary new vehicle registration, a newly assigned license plate number (this is the case, for example, when somebody changes their place of residence to another administrative district).
- The holder of the registration certificate is assigned a new license plate following the theft of their motor vehicle.
- The holder of the registration certificate is assigned a new license plate following the theft/loss of the license plate of their motor vehicle.

- The holder of the registration certificate will be assigned a new registration number to the newly registered motor vehicle due to damage to their motor vehicle as a result of an accident or force majeure which makes it impossible to participate in road traffic with this motor vehicle (total loss).
- The holder of the registration certificate receives a personalized license plate number.
- After waiving the personalized license plate number or after the personalized license plate has expired, a new license plate number is assigned to the holder of the registration for their vehicle.
- After the return of a license plate, which is no longer easily legible over the longer term, the holder of the registration is assigned a new license plate number in accordance with section 50 (2) KFG.
- In “similar cases” to the above mentioned in accordance with section 11(5) BStMG.

The next usage of the road toll network is only permitted if the change has been completed in the toll system. After the change of the digital annual vignette, the authorization to use the motorways and expressways with the old license plate number expires.

For a successful change, documents of proof need to be provided.

A change is possible in the Webshop (after registration and login) in the personal user account and – subject to the following provisions – also at toll stations, the ASFINAG Service Center and selected points of sale offering this service.

In the event of a change in the Webshop, the following proof documents must be uploaded or presented at the toll stations, at selected points of sale offering this service or at the ASFINAG Service Center:

- documents which prove that the requirements for a change after the beginning of validity of a digital annual vignette are met (e.g. proof of residence, proof of total loss, theft report, notice of loss)
- copy of the registration certificate of the particular vehicle’s license plate number that has been registered in the toll system, as well as the copy of the new vehicle’s registration certificate for the license plate that should be registered instead
- provision of the order confirmation respectively the product-ID (in case the change is requested at the ASFINAG Service Center)

In cases of doubt, ASFINAG or those points of sale offering this service are entitled to request further evidence.

3.6.1 Conditional changes in the ASFINAG Webshop

If any changes of the digital annual vignette is requested in the ASFINAG Webshop, the following steps are required:

- make an application for a conditional change
- upload appropriate documents of proof as *.pdf, *.jpg or *.tif

- Payment of an amount of EUR 18.00 including VAT. (this amount will be refunded under the conditions listed below). Regarding the possible means and methods of payment see Appendix 2.

The requested change in the Webshop is (provisionally) immediately effective and permits the driver for the time of ten calendar days (whereby the day on which the request has been made is not counted) to use the road network subject to tolls. Therefore, for this certain time period the digital vignette belonging to the previous license plate number expires.

During these ten calendar days ASFINAG will verify the uploaded documents of proof. In certain cases (e.g. change of residence within Austria), the verifying process can be automatically supported.

ASFINAG will try to inform the applicant about the proof status by the applicant's given e-mail address. Apart from that, there is the possibility to query the vignette registry at any time whether there is a valid digital vignette for the respective license plate number.

After a positive verification process the digital vignette will be permanently changed to the newly assigned license plate number.

Furthermore, the amount of EUR 18.00 incl. VAT will be refunded in the following cases:

- a newly assigned license plate number due to theft of vehicle
- a newly assigned license plate number due to theft/loss of the (originally registered) license plate number
- a newly assigned license plate number due to total loss
- a newly assigned license plate number due to the return of a license plate which is no longer easily legible in accordance with section 50 (2) KFG.

In the case of a change due to a newly assigned license plate number as a result of change of residence, assignment or expiration of the personalized license plate number, waiver of the personalized license plate number, as well as in similar cases the amount of EUR 18.00 incl. VAT will be considered as a reimbursement of expenses and therefore not be refunded.

If the verification process is negative, the (provisional) re-registration expires at the end of the tenth calendar day and the digital vignette is again valid for the originally registered license plate number. The paid amount of EUR 18.00 incl. VAT will be considered as a reimbursement of expenses and therefore not be refunded.

3.6.2 Changes at the ASFINAG Service Center

Changes in regard to the digital annual vignette can only be requested at the ASFINAG Service Center (see section 1.13) in the following cases:

- a newly assigned license plate number due to theft of vehicle

- a newly assigned license plate number due to theft/loss of the (originally registered) license plate number
- a newly assigned license plate number due to total loss

In this regard certain documents have to be submitted in order to grant the changes, whereby documents of proof are accepted in the following form: *.pdf, *.jpg or *.tif.

The requested re-registration only come into effect after the ASFINAG Service Center has finished the verification process with a positive result.

In case of a newly assigned license plate number due to change of residence respectively in similar cases, changes can only be made in the Webshop (see section 3.6.1) after paying the reimbursement of expense.

ASFINAG will inform about the result of the verification process. Apart from that, there is the possibility to query the vignette registry at any time whether there is a valid digital vignette for the respective license plate number.

After a positive verification process the digital vignette will be permanently changed to the newly assigned license plate number and permits the driver to use the road toll network. The digital vignette for the previous vehicle license plate number expires at this point.

3.6.3 Change of license plate number at toll stations and selected points of sale

In addition, the change of a license plate number of the corresponding digital annual vignette can be requested from toll stations and selected points of sale offering this service in the following cases:

- The holder of the registration certificate transfers their residence and a new license plate number is assigned to them due to the new registration of their motor vehicle (this is the case, for example, if a residence in Austria is transferred to another administrative district).
- The holder of the registration certificate is assigned a new license plate following the theft of their motor vehicle.
- The holder of the registration certificate is assigned a new license plate following the theft/loss of the license plate of their motor vehicle.
- The holder of the registration certificate will be assigned a new registration number to the newly registered motor vehicle due to damage to their motor vehicle as a result of an accident or force majeure which makes it impossible to participate in road traffic with this motor vehicle (total loss).
- The holder of the registration certificate receives a personalized license plate number.
- After waiving the personalized license plate number or after the personalized license plate has expired, a new license plate number is assigned to the holder of the registration for their vehicle.

- After the return of a license plate, which is no longer easily legible over the longer term, the holder of the registration is assigned a new license plate number in accordance with section 50 (2) KFG.

Suitable documents of proof must be submitted for the change of the license plate number.

As a condition for the change an amount of EUR 18.00 must be paid in the event of a change of residence, the assignment or the expiration or waiver of a personalized license plate.

The requested re-registration becomes effective after a positive verification process and from this point on entitles the holder to use the road network subject to tolls with the new license plate number. The digital vignette for the previous vehicle license plate number expires at this point.

The toll station or point of sale will issue a confirmation of the re-registration of the license plate number. The customer must check the confirmation to ensure that the data entered there (in particular the registered license plate number and the validity period of the digital vignette) are entered correctly. Any need for correction must be reported immediately to the toll collector or point of sale.

PART A II: TOLLING REGULATIONS FOR VEHICLES WITH A MAXIMUM TOTAL WEIGHT OF UP TO 3.5 T FOR EXISTING SECTION TOLLS ON THE AUSTRIAN MOTORWAY AND EXPRESSWAY NETWORK: A 9, A 10, A 11, A 13, S 16

1 GENERAL REGULATIONS

1.1 DEFINITION OF TERMS

- **valid digital section toll authorization:** This means that the vehicle license plate number is duly registered in ASFINAG's toll system for the time period of use of the section subject to toll payment and the section toll authorization is already valid.
- **order confirmation:** The document issued when a digital vignette has been obtained (registration in the toll system). This document particularly shows data of the license plate number registered in the toll system, vehicle type, validity period as well as the product-ID, which serves to clearly identify the digital vignette.
- **allonge:** The lower section of the toll sticker (backing paper/ toll sticker tab).
- **ASFINAG app:** If in the following the term ASFINAG app is being used, the ASFINAG app "Unterwegs" is meant.
- **vignette registry:** This term is used to define the publicly accessible registry on www.asfinag.at, which can be visited by any person without any costs, to view whether a license plate number is already registered in the toll system and therefore owns a digital vignette or a digital section toll ticket and for what time period it is valid.
- **Vehicle type:** Hereby a differentiation between single-track vehicles and twin-track vehicles with a maximum total weight of up to 3.5 t is made.
- **digital subscription:** A digital subscription is an unlimited obtainment of digital annual vignettes or digital annual cards similar to a subscription contract.

1.2 SCOPE OF APPLICATION

Tolling Regulations Part A II applies to all vehicles with a maximum total weight of up to 3.5 t (in short "category 1"). Unless expressly indicated otherwise, all references to individual sections contained in Part A II of the Tolling Regulations relate to sections in Part A II of the Tolling Regulations.

According to § 10 para. 3 last sentence of the BStMG [Federal Road Tolls Act], motor vehicles with three wheels are considered as single-track motor vehicles.

For multi-lane motor vehicles that have never been registered for traffic and carry test drive or transfer license plates, the tariffs of category 1 according to point 3 apply, provided their tare weight does not exceed 3.5 t. A copy of the type certificate shall be carried on journeys with test or transfer license plates and shall be presented upon request to the toll enforcement officers or toll staff.

No toll must be paid for trailers being towed by twin-track vehicles with a maximum total weight of up to 3.5 t.

1.3 ROAD SECTIONS ON WHICH TOLLS ARE LEVIED

1.3.1 Names of the section toll segments and toll stations

The table below lists the names of the toll sections respectively section toll segments, and toll stations that are the subject matter of and are subject to Tolling Regulations Part A II:

Motorway	Name of the toll section/section toll segment	Name of the toll station
The sections of the A 9 Pyhrn motorway between the Spital/Pyhrn and Ardnig junctions and between the St. Michael intersection and the Übelbach junction	Bosruck/Gleinalm	Toll station Bosruck
		Toll station Gleinalm
The section of the A 10 Tauern motorway between the Flachau and Rennweg junctions	Tauern/Katschberg	St. Michael i.L. toll station
The section of the A 11 Karawanken motorway between the St. Jakob im Rosental junction and the international border in the Karawanken tunnel;	Karawanken	Toll station Rosenbach
A 13 Brenner motorway	Brenner	Schönberg main toll station
The section of the S 16 Arlberg expressway between the St. Anton am Arlberg and Langen am Arlberg junctions	Arlberg	Toll station St. Jakob

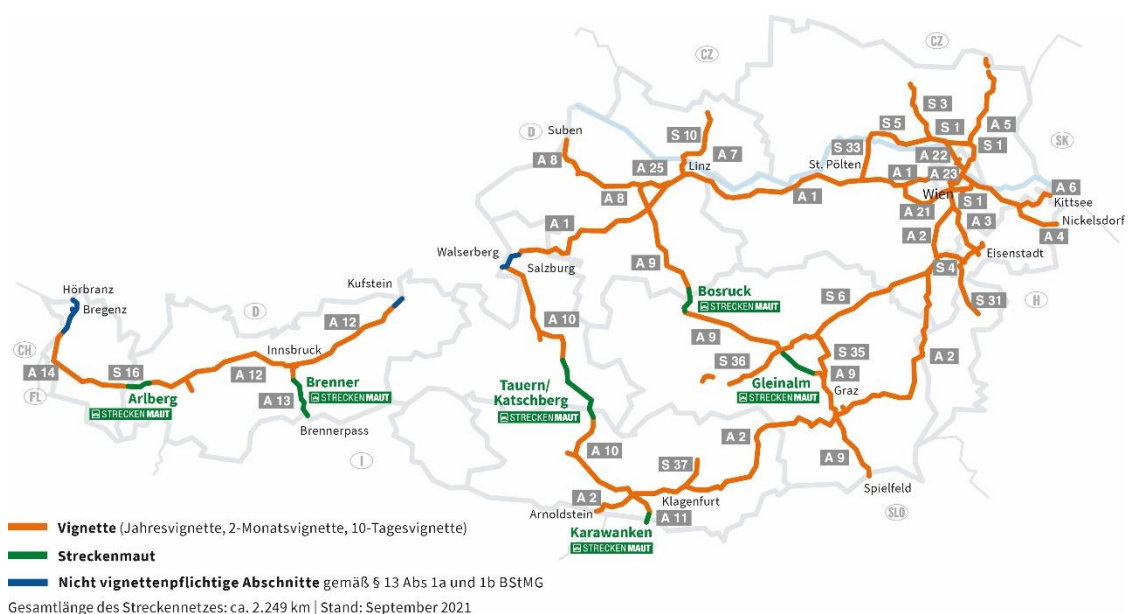

Figure 9

1.3.2 Signing

Drivers are notified of the toll obligation by appropriate mandatory signs at the start of each toll section.

1.4 JURISDICTION AND APPLICABLE LAW

The exclusive place of jurisdiction for all claims against ASFINAG under civil law arising out of these Tolling Regulations and/or the use of the road network subject to tolls shall be the court that has jurisdiction as regards such matters for the first district in Vienna. Only Austrian law applies, excluding the conflict of laws rules of private international law.

1.5 RESPONSIBILITY AND CUSTOMER SERVICE (ASFINAG Service Center)

All queries or applications for refunds should be addressed to ASFINAG Maut Service GmbH:

ASFINAG Maut Service GmbH

Alpenstraße 99

A-5020 Salzburg, Austria

Tel.: 0800 400 12 400 (free of charge from Austria and Germany)

Tel.: +43 (1) 95 51 266 (not free of charge when calling from all other countries)

Fax: +43 (1) 95 51 277

E-Mail: info@asfinag.at / <http://www.asfinag.at>

2 OBLIGATION TO PAY THE SECTION TOLL

Vehicles may only drive through existing toll stations on the specially marked lanes. Depending on traffic volume, so-called open toll lane operation or mixed toll lane operation may be used on these lanes.

2.1 MIXED TOLL LANE OPERATION

During mixed lane operation (see figure 9a, 9c and 9d), the toll lane may be used by both vehicles with a maximum total weight of up to 3.5 t and vehicles with a maximum total weight of more than 3.5 t (see Tolling Regulations Part B). Instructions given by the toll station personnel must be followed. There are no special toll lane operation signs at the secondary toll stations at the Zederhaus and St. Michael/Lungau junctions on the A 10 and the Zenzenhof, Igls Patsch, Schönberg Stubaital, Matriei Steinach, Nösslach, and Brennersee junctions on the A 13.

2.2 OPEN TOLL LANE OPERATION;

2.2.1 Open toll lane operation on A10, A11, A13 and S16

During open toll lane operation, one lane is reserved for vehicles that are liable for the distance-related toll. These lanes will be clearly marked as such (see figure 9b).

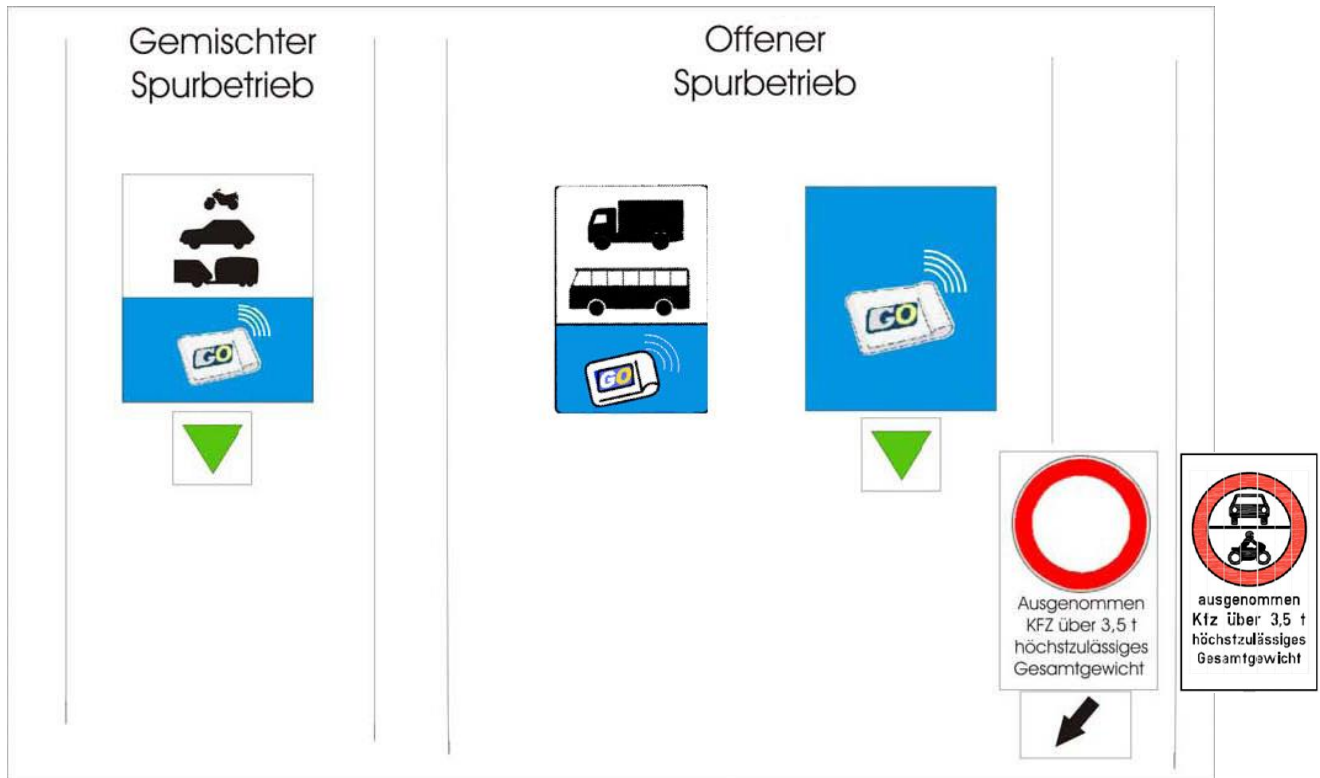

Figure 9a: 'mixed lane operation'

Figure 9b: 'open lane operation'

In open toll lane operation, motor vehicles with a maximum permissible total weight of up to and including 3.5t (category 1) are prohibited from driving on this toll lane in accordance with the StVO. Category 1 vehicles are not permitted to use this lane. Drivers who violate this prohibition are in breach of an administrative rule (see section 7).

2.2.2 Open toll lane operation on A 9

In open lane operation at the toll stations on the A9 (Bosruck, Gleinalm), two lanes each are open for motor vehicles with a maximum permissible total weight of up to and including 3.5 t whose licence plates have a valid digital section toll authorisation for the Bosruck/Gleinalm section toll segment (see points 1.1., 1.3.1) or are released for the digital section toll Flex (see point 4.2.2). These lanes are specially marked (by green road markings and green signs or with the words "Prepaid Only"). These lanes can also be used in mixed lane operation (i.e. both by vehicles with a maximum permissible total weight of over 3.5 t (see tolling regulations part B) and by vehicles with a maximum permissible total weight of up to 3.5 t) (see Figure 9c).



Figure 9c

Motor vehicles whose vehicle license plate numbers are not properly registered in the toll system for the Bosruck/Gleinalm section toll segment (i.e. which do not have a valid digital section toll or digital section toll Flex) must be allocated to those lanes which allow tolls to be paid locally at the toll station. These lanes are specially marked (without special road marking, but with signs in white or with the indication "Buy Ticket") (see Figure 9d).

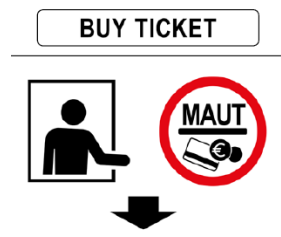

Figure 9d

Use of the open lanes without having properly paid the toll constitutes an administrative offence (see point 7).

2.2.3 Special obligations to cooperate A 9

If the driver of a motor vehicle subject to tolls intends to use the open lanes of the Bosruck or Gleinalm toll stations on the A 9, they must ensure that the toll for the relevant section of the toll road has been properly paid. This is done by querying the vehicle registration number in the vignette record (see point 1) immediately before using the toll road (road toll section), which provides information as to whether a motor vehicle has a valid digital road toll, for which road toll section and for which period of time it is valid.

Furthermore, every vehicle driver has to – according to section 102(2) KFG – make sure that the official license plate number of the vehicle that is liable for toll, is completely and permanently visible during the journey and has not been covered by dirt or snow, respectively damaged deformed in such a way that it is illegible.

2.3 EXEMPTIONS FROM THE TOLL OBLIGATION

2.3.1 Permanent exemptions

The following vehicles are exempt from the toll obligation:

- Motor vehicles on which headlights or warning lights with blue light are visibly attached according to § 20 para. 1 no. 4 KFG, as well as motor vehicles of the public security service, the tax administration, the judicial guard, foreign security authorities according to § 2 para. 3 of the Police Cooperation Act, foreign customs and judicial authorities and motor vehicles of the firefighting associations on which headlights or warning lights with blue light are visibly attached according to § 20 para. 5 KFG. The exemption from the toll obligation shall be applied for in writing to ASFINAG by 30 September of each year for the following year and it

shall be demonstrated by appropriate evidence that the conditions set forth in this provision are met and for which motor vehicles the exemption is applied for.

- Vehicles with visible blue headlights or warning lights in accordance with section 20(5) of the KFG and registered in the name of non-profit institutions, the tasks of which are fulfilled mainly by voluntary workers. The regular use of motor vehicles for the purposes of these devices (or of a device mentioned in § 20 para. 1 Z 4 KFG) shall be deemed equivalent to a licence if headlamps or warning lights with blue light are visibly attached to the motor vehicles in accordance with § 20 para. 5 KFG. The respective institution shall apply for the exemption from the toll obligation to ASFINAG in writing by 30 September of each year for the following year and shall provide appropriate evidence that the conditions laid down in this provision are fulfilled and for which motor vehicles the exemption is applied for.
- Vehicles with flashing blue light in accordance with section 2(1)(25) StVO 1960, BGBl. No. 159 (operational vehicles) for the time one of these signals is used, whereby ASFINAG is authorised to randomly check the correctness of the declaration that the vehicle has been operationally used by contacting the appropriate command and control centre afterwards. The exemption of the toll obligation is also valid for the return journey in case the signals have been used.
- Army vehicles (section 2(1)(38) Motor Traffic Act 1967).
- Vehicles that are used within the scope of the agreement among the states party to the North Atlantic Treaty and the other states participating in the Partnership for Peace regarding the status of their forces ('PfP-SOFA'). If non-military vehicles are used for these trips, they shall provisionally be subject to the toll provisions. The toll paid in the course of these trips will be refunded by ASFINAG free of charge. The request for reimbursement must be submitted by the respective competent state authority directly to ASFINAG Maut Service GmbH (see Appendix 7b) after completion of the journeys, together with the relevant evidence.
- Motor vehicles used in the performance of peace-keeping operations within the framework of an international organisation, the Organisation for Security and Cooperation in Europe or the European Union pursuant to a decision taken under the common foreign and security policy.
- Confiscated vehicles that use the road network subject to tolls and to which an official tax authority registration number has been attached are not liable for the toll. The tax authority has to request an exemption from ASFINAG in advance and in written form.

Vehicles that have blue headlights or warning lights visibly attached to the exterior, but are not registered and therefore carry transfer license plates or other equivalent plates and that use the road network subject to tolls are not exempt from the toll obligation.

2.3.2 Temporary exceptions

2.3.2.1 Exceptions for humanitarian aid transports

In addition to the above provision, ASFINAG may in accordance with section 5(2) BStMG and depending on the circumstances, exempt vehicles with a maximum total weight of up to 3.5 t that are delivering humanitarian aid in the event of emergencies or disasters from paying the toll obligation.

In order to be able to carry out such a journey without being obliged to pay the toll at a toll station (en-section toll), the application for exemption in accordance with Appendix 3c (which can be

downloaded from www.asfinag.at) must be completed, duly signed and submitted by e-mail (info@asfinag.at) or by fax (+43 / 1 955 12 77) at least 24 hours before use of the road network subject to toll. The applicant will receive confirmation.

The fully completed and signed application form (original) containing the issued application number must be handed over at the relevant toll station. If a return journey is to be made, a copy of the original application form must be made and handed over at the toll station on the return journey.

This provision applies without exception only in the event of an incident within the meaning of § 5 para. 2 BStMG and the specific incident is announced in the tolling regulations at this point.

2.3.2.2 Exceptions at the request of the Federal Ministry of the Interior (BM.I) in the context of state crisis and disaster control management or international disaster aid

At the request of the Federal Ministry of the Interior (BM.I), trips carried out by motor vehicles with a maximum permissible total weight of up to 3.5 t within the framework of state crisis and disaster protection management or international disaster relief may be exempted from the payment of tolls on a case-by-case basis.

To enable such trips to be made without the obligation to pay the toll (section toll), the Federal Ministry of the Interior (BM.I) must notify ASFINAG of these trips, listing the license plate number of the motor vehicles concerned and announcing the expected route and the exemption period before using the road network subject to toll payment.

The written confirmation of the Federal Ministry of the Interior (BM.I) concerning the concrete exception to the toll duty during the toll-free trip must be carried in the affected motor vehicles and presented on request as proof of entitlement.

3 TOLL RATES

Each toll rate includes 20% VAT and is explained in the tables below.

Amendments to the toll rates during the period of validity of the various pre-paid toll cards do not have any bearing on the toll rate already paid. Such amendments shall not, therefore, result in any claims from whatever party regarding additional payment or refund of the toll difference.

3.1 STANDARD TOLL RATES

The following toll rates apply to the section toll segments:

3.1.1 A 9 Gleinalm and A 9 Bosruck

Category 1	Card type	Price	Gleinalm	Bosruck
A 9 Gleinalm Bosruck	Single trip		€ 9.50	€ 6.00
	Annual card	€ 109.50		
	Jk. Commuter ⁽¹⁾		€ 43.50	€ 43.50

(1) see section 3.2.4.

3.1.2 A 10 Tauern/Katschberg

Category 1	Card type	Price	Total toll section	Toll road subsection
A 10 Tauern/Katschberg	Single trip		€ 12.50	€ 6.50
	Annual card	€ 115.00		
	Jk. Commuter ⁽¹⁾	€ 43.50		

(1) see section 3.2.4.

3.1.3 A 11 Karawanken

Category 1	Card type	Price	Price per trip
A 11 Karawanken	Single trip		€ 7.60
	14-trip monthly card ⁽¹⁾	€ 34.10	€2.44

(1) see section 3.2.9.

3.1.4 A 13 Brenner

Category 1	Card type	Price	Total toll section	Toll road subsection 1	Subsection 2	Subsection 3	Subsection 4
4 Brenner	Single trip		€ 10.00	€ 1.00	€ 2.50	€ 3.50	€ 5.00
	Annual card	€ 109.50					
	Jk. Commuter ⁽¹⁾	€ 43.50					
	Monthly card ⁽²⁾	€ 43.50					

(1) see section 3.2.4.

(2) see section 3.2.7.

Total toll section: Every trip past the main toll station

Toll road subsection 1: Innsbruck - Zenzenhof or Brenner Pass - Lake Brenner and vice versa

Toll road subsection 2: Innsbruck - Patsch/Europa Bridge or Brenner Pass - Nösslach and vice versa

Toll road subsection 3: Innsbruck–Stubaital and in the other direction

Toll road subsection 4: Matri - Brenner Pass and vice versa

3.1.5 S 16 Arlberg road tunnel

Category 1	Card type	Price	Price per trip
S 16 Arlberg Tunnel	Single trip		€ 10.50
	Annual card	€ 109.50	
	Jk. Commuter ⁽¹⁾	€ 43.50	

(1) see section 3.2.4.

3.2 TYPE OF RATES

The options to pay the toll are explained in section 4.

3.2.1 Single trip

A single trip ticket is valid for one year from the date of issue and permits to use a particular section toll segment for one direction.

3.2.2 Annual card (without vignette credit)

The annual card is tied to the vehicle's license plate number and has a validity period of one year, whereby the first day of validity can be chosen freely during the purchasing process. The last possible first day of validity of an annual card from the current calendar year is 31 December. An annual card entitles the user to an unrestricted use of a particular section toll segment. There is no annual card available for the A 11 Karawanken motorway.

3.2.3 Annual card with vignette credit

In accordance with section 13(10)(2) BStMG, the presentation of the allonge (toll sticker tab) or the product-ID of a valid annual vignette for the same passenger car's or motorcycle's vehicle registration number entitles the holder to a once-off credit of €40.00 (including 20% VAT) against the purchase price of an annual card for one particular section toll segment.

3.2.4 Annual card for commuters

The annual card for commuters is valid for one year from the date of issue. For all toll roads, with the exception of the A 11 Karawanken motorway, annual cards for commuters can be obtained if the following conditions are fulfilled:

- The applicant is employed (also applies to conscripts).
- Verifiable and plausible confirmation of the place of residence and place of work are provided. Use of the toll road must either be unavoidable or at least constitute the shortest distance.
- The annual card for commuters is only issued for one vehicle registered in the commuter's name.

In accordance with section 13(10)(1) BStMG, the presentation of the allonge (toll sticker tab) or the product-ID of a valid annual vignette for the same license plate number entitles the holder to a free annual card for commuters. For each subsection of the section toll segment A 9 Bosruck/Gleinalm the aforementioned requirements will be checked individually.

3.2.5 Annual card for disabled drivers

The annual card for disabled drivers is valid for one year from the date of issue and can be obtained for €7.00 (including 20% VAT) if the following conditions are fulfilled:

- Presentation of a disabled person's parking permit (according to section 29b StVO)

- An entry in the valid driver's license indicating that the holder is restricted to driving disability-adapted vehicles – the entry that they are restricted to driving vehicles with automatic transmission is the minimum requirement.
- The annual card for disabled drivers is only issued for one vehicle registered in the disabled driver's name.

The card is also issued in the name of the beneficiary and is, in derogation of the general regulations for annual cards, valid for all ASFINAG section toll segments (Tolling Regulations Part A II), with the exception of A 11 Karawanken motorway.

3.2.6 Annual card for disabled drivers on the A 13

An annual card for disabled drivers on the A 13 is valid for one year from the date of issue and can be obtained for €43.50 (including 20% VAT) if the following conditions are fulfilled.

This card can be obtained by:

- holders of official certificates and victim's identity cards whose reduction in earning capacity is at least 50%
- seriously disabled people according to section 9(2) of the War Victims Welfare Act
- blind civilians in possession of a blind person's identity card;
- disabled people who can provide evidence that they suffer from at least 50% disability.
- The annual card for disabled drivers is only issued for a vehicle registered in the name of a disabled driver.

This annual card is valid for the A 13 Brenner motorway only.

By presenting the allonge (toll sticker tab) or the product-ID of a valid annual vignette for the same license plate number the annual card for disabled drivers is free of cost.

3.2.7 Monthly card for the A 13

This monthly card is restricted to one particular vehicle registration number and entitles the driver to an unlimited number of trips on the A 13 Brenner motorway within 30 calendar days from the date of issue. The card, which can be obtained for €43.50 (incl. 20% VAT), is issued upon presentation of the vehicle registration certificate.

3.2.8 Resident's card for the A 13

Inhabitants of the municipalities of Ellbögen, Gries am Brenner, Gschnitz, Matri am Brenner, Mühlbachl, Navis, Obernberg am Brenner, Patsch, Pfons, Schmirn, Steinach am Brenner, Trins, and Vals in the Wipp Valley (Wipptal) and the municipalities of Schönberg, Mieders, Fulpmes, Telfes, and Neustift in the Stubai Valley (Stubaital) will receive resident's cards as long as they meet the conditions listed directly below:

- The holder of the registration certificate is a natural person.
- A valid confirmation of the applicant's main place of residence is provided.

- The resident's card is only issued for a vehicle registered in the applicant's name.
- The vehicle is registered in the name of a private person only and is not used as a company vehicle.

The resident's card for the A 13 is valid for one year from the date of issue and can be purchased for the price of EUR 43.50 (incl. 20% VAT) if the requirements are fulfilled. By presenting the allonge (toll sticker tab) or the product-ID of a valid annual vignette for the same license plate number the resident's card is free of cost.

3.2.9 14-trip monthly card for the A 11

This is a card linked to the vehicle via the vehicle registration number. It entitles the holder to 14 journeys through the Karawanken tunnel during 30 calendar days from the date of issue of the card. Unused trip credits cannot be refunded at the end of the 30 calendar days.

3.3 LOSS OF LICENSE PLATE NUMBER RELATED CARDS

In the event of loss of a license plate number related card, a new card can be issued for EUR 7.00 (incl. 20% VAT) at the toll station as reimbursement of expenses.

4 PAYMENT METHODS

4.1 PAYMENT AT THE TOLL STATION

The toll must be paid in EUROS at the toll stations. Information regarding other acceptable means and methods of payment is given in Appendix 2 and on the Internet at www.asfinag.at. This information may also be obtained from customer services (see information in section 1.5).

4.2 PURCHASE IN ADVANCE

4.2.1 Purchase in the Webshop and the ASFINAG App: Payment in advance - Pre-Pay

Single-trip tickets (section 3.2.1), annual cards (section 3.2.2) as well as annual cards with vignette credit (section 3.2.3) are also offered in the Webshop and in the ASFINAG app.

The purchase is possible in the Webshop or by using the ASFINAG app from within Austria, the European Union as well as in the EEA states and Switzerland.

In regard to the beginning of validity and the required minimum details, the regulations mentioned in Part A I, section 3.2.1.1 and 3.2.1.2 are in corresponding effect. Please refer to 4.3.2 and 4.4 regarding the service for obtaining the digital subscription for digital annual cards without vignette credit (3.2.2) and for digital annual cards with vignette credit (3.2.3) and the associated specific features.

When purchasing single-trip tickets immediate validity can be demanded. Further information is available in the terms of use on www.asfinag.at.

4.2.2 Pre-registration in the Webshop and the ASFINAG App: Retroactive payment - Digital Route Toll Flex

Single trips (item 3.2.1) are also offered in the Webshop and the ASFINAG App for retroactive payment (Digital Route Toll Flex).

Registration for Digital Route Toll Flex can be made through the Webshop or the ASFINAG App (item 4.3.3). This is possible via the webshop and the ASFINAG app from within Austria, the EU, as well as the EEA states and Switzerland.

As soon as the registration process has been successfully completed in the Webshop or the ASFINAG App, the license plate is registered for the purposes of the Digital Route Toll Flex. From this time the license plate will also be shown in the vignette registry. As long as the license plate appears in the vignette registry, the Digital Route Toll Flex service shall be deemed to have duly paid the section toll for the respective toll section in the sense of § 32 (1) BStMG for the use of the toll section.

If collection is not possible from the payment method deposited at the time the toll section is used (for whatever reason), the Digital Route Toll Flex service will be blocked at the end of the same day. From this time the license plate no longer appears in the vignette registry.

In the event of the service being blocked, the correct payment of the section toll is only possible if the Digital Section Toll Flex service is "reactivated" or an alternative payment option is used.

Before each journey, the driver must ensure that the license plate has been activated to enable the correct payment of the section tolls by the Digital Route Toll Flex service by querying the license plate in the vignette registry.

4.2.3 Purchase at the vending machine

The range of products is limited at the vending machines. They are freely accessible. Further information on their location and the range of products is available on www.asfinag.at.

In regard to the beginning of validity and the required minimum details, the regulations mentioned in Part A I, section 3.2.2.1 and 3.2.2.2 are in corresponding effect.

4.2.4 Purchase at sales points

Single-trip tickets (section 3.2.1), annual cards (section 3.2.2) as well as annual cards with vignette credit (section 3.2.3) can be purchased at certain sales points. Further information is available in the terms of use on www.asfinag.at.

In regard to the beginning of validity and the required minimum details, the regulations mentioned in Part A I, section 3.2.3.1 and 3.2.3.2 are in corresponding effect.

4.2.5 Means of payment

The payment in the Webshop, with the ASFINAG app and at vending machines must be made in euros. Information on which methods of payment respectively means of payment, are accepted in

the Webshop, the ASFINAG app and at the vending machines is available in Appendix 2 as well as on www.asfinag.at respectively at the customer service (see information in section 1.5).

The accepted means of payment at the sales points can differ, depending on the sales point and should be requested from the sales point.

4.3 ADDITIONAL SERVICES ("My Account")

4.3.1 General services

In the Webshop as well as in the ASFINAG app, it is possible to create a personal user account ("My Account") at any time (i.e. even after completion of the purchase process) by entering access data. The regulations of Part A I, section 3.2.5.1 are in corresponding effect.

4.3.2 Digital subscription in the personal user account ("My Account")

It is possible to take out a digital subscription in the Webshop, that is a subscription for an indefinite period for obtaining, managing (for example by keeping credit card details up to date) and cancelling digital annual cards without vignette credit (see 3.2.2) and annual cards with vignette credit (see 3.2.3) in subsequent years.

The regulations of Part A I, 3.2.5.2 apply accordingly with the following distinctive features:

- **Validity:** When purchasing a digital annual card for the first time (= initial acquisition) customers can select the first day of validity for the digital annual card in accordance with Part A I, 3.2.1.1. Subsequent purchases of digital annual cards within a digital subscription follow on seamlessly from the validity period for the currently valid annual card and are determined by the first day of validity for the digital annual card as selected by the customer.

Example: A customer purchases a digital annual card and decides to take out a digital subscription as well. The customer chooses the 28th of September as the first day of validity for the digital annual card when purchasing the first card. The last day of validity of this initial purchase is therefore 27 September of the following year. The first day of validity of a subsequent purchase is 28 September of the following year.

- **Information for customers:** In order to obtain the digital subscription, providing an e-mail address is required. At least 20 days before payment is collected, the customer receives information, particularly on the date of the upcoming collection of payment (collection of the acquisition price of the annual card), the amount to be collected (including information as to whether a credit for an annual vignette is already included in the stated price (see 3.2.3) or under what conditions an annual vignette will be credited) and the last possible date by which cancellation of the digital subscription for subsequent payments is possible. This e-mail address is also used to inform the customer whether collection of payment was successful.

- *Successful transaction:* Following successful collection and thus the acquisition of a digital annual card, the customer is informed via the e-mail address specified by the customer and sent the order confirmation and invoice for the transaction. In this case the digital annual card is valid as from the day following the last day of validity of the previous annual card.
- *Unsuccessful transaction:* The customer is also informed about this via an e-mail to the e-mail address specified by them. If collection is not possible (for example because the credit card specified is no longer valid), this counts as timely cancellation of the digital subscription. In this case, the entitlement to use toll roads ends on the last day that the existing annual card is valid.
- Cancellation of the digital subscription: Cancellation of the digital subscription can only be made in the personal user account ("My Account") without giving reasons.

4.3.3 Retroactive payment of single journeys (Digital Route Toll Flex) in the personal user account ("My Account")

In the Webshop and the ASFINAG App there is the possibility to set up the payment of single journeys retrospectively (Digital Route Toll Flex). Within the framework of the Digital Route Toll Flex, a payment method accepted by ASFINAG (see Appendix 2) is stored for one or more vehicle license plates and the respective tariff for single journeys (Item 3.2.1) is paid retroactively by this payment method (Digital Route Toll Flex). The webshop and the ASFINAG app can be used to register vehicle license plates for the Digital Section Toll Flex service, to manage the registration data (for example to update credit card data) and to cancel the Digital Section Toll Flex service.

The accepted options and means of payment are mentioned in Appendix 2.

4.4 Terms of use

Further information on the purchase of the Digital Route Toll in the Webshop and the ASFINAG App, on the purchase of the Digital Subscription and on the payment option Digital Route Toll Flex, on the required information and the steps to be taken, as well as on the other services are available in the respective Terms of Use, which can be downloaded from www.asfinag.at.

In addition, customers may, upon request, inspect the current tolling regulations and the privacy policy (www.asfinag.at/privacy) at points of sale at any time.

4.5 RIGHT OF WITHDRAWAL

If the digital section toll has been paid for by means of distance communication, (in the Webshop or with the ASFINAG app) the customer can withdraw from purchase without any particular reasons given, within 14 days from the day on which the digital section toll has been paid for.

In order to exercise the right of withdrawal, ASFINAG must be informed of the decision to withdraw from the subscription by means of a clear statement. The withdrawal period shall be respected when the withdrawal notice is sent within the deadline.

In the case of single journeys, the customer's right to withdraw from the contract lapses upon commencement of the single journey (passing through the toll station) if the customer has chosen to make immediate use of the single journey in the Webshop or in the ASFINAG App. This shall also apply to single journeys which are processed and paid for using the Digital Route Toll Flex (Item 4.2.2 or 4.3.3).

There is no right of withdrawal in the event of purchase at a toll station, point of sale or at a vending machine. This also applies if an annual card is purchased as a follow-on purchase as part of a digital subscription.

More detailed information on the declaration of withdrawal as well as on the refund of payments made is available in the terms of use on the internet at www.asfinag.at.

4.6 SPECIFICS FOR ENTREPRENEURS

The regulations in Part A I, section 3.4. correspondingly apply to entrepreneurs who purchase the digital section toll within their work as entrepreneurs.

4.7 POSSIBLE CHANGES

When it comes to single-trips, the license plate number and state of registration registered in the toll system can be changed before using the section toll segment.

In the case of an annual card, the license plate number and state of registration can be changed, if the validity has not started yet. Furthermore, the first day of validity can also be changed, whereby the following must be taken into account:

- If the annual card has been obtained in the Webshop or in the app, the first day of validity may not be before the 18th day, 0:00 hours after the obtainment.

Example: An annual card was purchased in the Webshop on 15 January. The earliest possible validity start date is therefore February 02, 0:00 hours.

- The first day of validity may not be changed to a day in the past – at the time of the change

Example: An annual season ticket with a validity start date of April 1 was purchased. If the first day of validity of this annual card is changed on 25 March, please note that the new start of validity must not be postponed to 24 March or before (i.e. into the past).

- Basically, the beginning of validity can be changed to the day on which the change is being made, whereby the permission to use the section toll segment only begins at the time of change.

Example: If today at 14:07 the beginning of validity of an annual card is changed to today, the permission to use the section toll segment starts at 14:07. The use of the section toll segment before that time referring to that annual card is prohibited and can constitute a toll evasion offence.

- The first day of validity can only be changed within the calendar year.

Example:

Possible: Postponement from 1 April to 1 October of the same calendar year.

Not possible: Postponement from 1 October of the current year to 1 February of the following year. It is also not possible to postpone from 1 February to 1 October of the previous year.

The at the beginning defined and allowed changes can be made by meeting the following requirements:

- In the Webshop and with the ASFINAG app (after the registration and login) in the personal user account (see section 4.3)
- At the customer service centre, at toll stations or at the point of sale where the digital section toll was purchased, by providing the order confirmation respectively product-ID, a copy of the registration certificate of the particular vehicle's license plate number that is currently registered in the toll system, as well as a copy of the new vehicle's registration certificate for the license plate that should be registered instead, when changing the vehicle's license plate number
- At the toll station by providing the order confirmation respectively product ID, a copy of the registration certificate of the particular vehicle's license plate number that is currently registered in the toll system, as well as a copy of the new vehicle's registration certificate for the license plate that should be registered instead, when changing the vehicle's license plate number.

In case of doubt, ASFINAG or the point of sale shall be entitled to demand further evidence.

4.8 RE-REGISTRATION FROM THE BEGINNING OF VALIDITY

If the validity of an annual card has already started, a change of the vehicle's license plate number, which is already registered in the toll system, to a new license plate number of the same holder of the registration certificate can only be requested in the following cases:

- The holder of the registration certificate changes their place of residence and receives, due to the therefore necessary new vehicle registration, a newly assigned license plate number. (This is the case, for example, when somebody changes their residence to another administrative district).
- The holder of the registration certificate receives a newly assigned license plate number due to the theft of their vehicle.
- The holder of the registration certificate is assigned a new license plate following the theft/loss of the license plate of their motor vehicle.
- The holder of the registration certificate will be assigned a new registration number to the newly registered motor vehicle due to damage to their motor vehicle as a result of an accident or force majeure which makes it impossible to participate in road traffic with this motor vehicle (total loss).
- The holder of the registration certificate receives a personalized license plate number.

- After waiving the personalized license plate number or after the personalized license plate has expired, a new license plate number is assigned to the holder of the registration for their vehicle.
- After the return of a license plate, which is no longer easily legible over the longer term, the holder of the registration is assigned a new license plate number in accordance with section 50 (2) KFG.
- In “similar cases” to the above mentioned in accordance with section 11(5) BStMG.

The next usage of the section toll segment is only permitted if the registration of the newly assigned license plate number has been completed in the toll system. After the changes of the annual card, the authorization to use the section toll segment with the originally registered license plate number expires.

The regulations mentioned in Part A I, section 3.6 on providing documents of proof, on the conditional change of the license plate number in the ASFINAG Webshop, on the change of the license plate number in the ASFINAG Service Center and change of the license plate number at toll stations and selected points of sale are correspondingly valid.

It is expressly pointed out that an amount of EUR 18.00 including VAT must also be paid upon application for a re-registration of an annual card in the Webshop. In the cases mentioned in Part A I, Item 3.6.1, this amount will be refunded if the verification process is positive.

In the event of change because the vehicle has been issued with a new license plate as a result of a change of residence, the assignment or expiration of the personalized license plate number, waiver of a personalized license plate or for similar reasons, as well as in the event of a negative verification process, the amount of EUR 18.00 including VAT will be kept as compensation for expenses and no refund will be made.

Furthermore, a change is also possible at the ASFINAG toll stations or at selected points of sale (see section 1.3.1) in the above mentioned cases. The relevant provisions of Part A I, section 3.6.3 are correspondingly valid.

For the re-registration it is necessary to provide the original toll card, the order confirmation or product ID at the toll station, or submitted to the selected point of sale offering this service, as well as copies of the documents proving that the requirements for a change have been fulfilled (see Tolling Regulations Part A I, section 3.6).

A fee of EUR 18.00 shall be payable at the toll station or at the selected points of sale in the event that the vehicle has been issued with a new license plate as a result of a change of residence, assignment or expiry of a personalized license plate or waiver of the personalized license plate. In all other cases a change can be made at no cost (see also Part A I, section 3.6).

The requested re-registration becomes effective after a positive verification process and from this point on entitles the holder to use the road network subject to tolls with the new license plate number. The annual card for the previous vehicle license plate number expires at this time.

The toll station or point of sale will issue a confirmation of the re-registration of the license plate number. The customer must check the confirmation to ensure that the data entered there (in

particular the registered license plate number and the validity period of the annual card) are entered correctly. Any need for correction must be reported immediately to the toll collector or point of sale.

Customers should notice that – when using roads on which the vignette is mandatory in order to approach a toll station – for the use of motorways and expressways on which the vignette is mandatory, the toll has to be paid properly and in accordance with the provisions of Part A I; otherwise, a toll evasion offence in accordance with Part A I, section 1.9 will have been committed.

5 DATA PROTECTION AND DATA SECURITY

ASFINAG is entitled pursuant to § 16a BStMG to process the personal data required for toll collection, toll collection and the prosecution of toll evasion with the aid of automation. Furthermore, ASFINAG is also entitled to process personal data which is required for the vignette registry (see section 1.1) in accordance with section 16 BStMG.

To verify if the toll has been paid properly and to trace toll evasion, in accordance with section 19a BStMG, ASFINAG is entitled to use technical equipment. The image data and the license plate number and control data obtained from it may be processed for the purposes of collecting the toll, requesting payment of a substitute toll or the information letter pursuant to section 30b para. 1 BStMG and prosecuting toll evasion.

More detailed explanations of the data protection principles and information on the rights of data subjects are available on the internet at www.asfinag.at.

6 MONITORING CORRECT PAYMENT OF THE SECTION TOLL

6.1 TOLL ENFORCEMENT OFFICERS

The toll enforcement officers are organs of public supervision. They are appointed and sworn in in accordance with the provisions of § 17 (2) BStMG.



Figure 10

When discharging their duties, toll enforcement officers must carry with them the identification card defined below and show it to the person concerned when requested to do so. The ID card of the toll enforcement officers, which confirms their official status, is the size of a credit card, is printed on both sides and contains the following information in particular: the photograph, name and service number of the toll enforcement officer (see Figure 11).



Figure 11

The toll enforcement officers' vehicles are public security force enforcement vehicles that comply with section 20(1)(4) lit.a of the Motor Vehicle Act 1967. These vehicles are silver-grey operational vehicles that are equipped with flashing blue lights and a siren. Furthermore, they are marked with the following words: "ASFINAG", "toll enforcement" and "ASFINAG service and toll enforcement unit" (see Figure 12).



Figure 12

For the purpose of checking that tolls as well as time-related tolls and section tolls have been paid correctly, the toll enforcement officers have the right, among other things, to request drivers to stop by using clearly visible or audible signs, to stop them, to check the affixing of the toll sticker or the registration of the license plate in the toll system, to establish the identity of the driver and of the holder of the registration certificate, the motor vehicle (in particular the registration certificate), – in the case of journeys with test or transfer license plates within the meaning of point 1.2 – to check evidence of the vehicle's tare weight (in particular a copy of the type certificate), and to ask drivers to pay any substitute toll due.

In addition, the toll enforcement officers are authorised to take motor vehicles, with the aid of automatic traffic guidance systems, to the toll auditing stations currently located at A1 Eberstalzell, A1 Haag, A1 Walserberg, A2 Arnoldstein, A2 Arnwiesen, A2 Haimburg, A2 Ilztal, A6 Kittsee, A4 Bruck/Leitha, A4 Nickelsdorf, , A4 Gols, A4 Zurndorf, A5 Schrick, A8 Kematen, A8 Suben, A9 Liesingau, A9 Liezen, A9 Schoberpaß, A9 Straß, A9 Trieben, A9 Übelbach, A9 Windischgarsten, A10 Hoher Göll, A10 Kellerberg, A11 Rosegg, A11 Karawanken Tunnel, A12 Roppener Tunnel east portal control bay, A12 control bay Zirl Ost, A12 exit Wörgl-Ost, A14 Hörbranz, A14 Nüziders, S4 Pötsching, S3 Göllersdorf, S16 the Bings snow chain mounting area, S31 Hirm Nord, S31 Hirm Süd and S37 Maria Saal for the purpose of checking that tolls have been paid correctly and to carry out traffic surveys. Additionally, toll enforcement officers may also monitor the correct payment of tolls and conduct traffic surveys at border crossings and junctions.

If the substitute toll is not paid and if criminal prosecution or enforcement of the penalty appears to be impossible or significantly impeded, toll enforcement officers are authorized in accordance with § 27 BStMG to collect a provisional security or, until the stipulated provisional security is paid, to

order the interruption of the journey in accordance with § 28 BStMG and to prevent its continuation using suitable precautions (confiscation of the vehicle keys and documents, attachment of technical barriers to the vehicle to prevent it being moved, parking at a suitable location, etc.).

6.2 CONFISCATION OF LICENSE PLATE NUMBER RELATED CARDS

Toll enforcement officers are entitled to confiscate license plate number related cards in case these cards are used for not permitted vehicles.

7 TOLL EVASION

7.1 PENALTIES FOR TOLL EVASION

Drivers who use – according to Part A II – sections on which tolls are levied (section toll segments) without paying the required toll amount properly are in breach of an administrative rule, which is a toll evasion in accordance with section 20(1) BStMG. This breach of an administrative rule will be fined between €300.00 and €3,000.00 by the local district administrative authorities.

Examples of such an administrative offence are:

- The driver of a motor vehicle with a maximum permissible total weight up to and including 3.5 t (category 1) uses the open lane of a toll station (see Part A II, item 2.2 "Open toll lane operation").
 - This lane is only open for motor vehicles with a maximum permissible weight of more than 3.5 t (see 2.2.1 "Open toll lane operation on A10, A11, A13 and S16"). According to the German Road Traffic Regulations (StVO) driving on this lane is prohibited for motor vehicles with a maximum permissible total weight of up to 3.5 t.
 - The driver of a motor vehicle with a maximum permissible total weight of up to and including 3.5 t (category 1) uses the open lane of the Bosruck and/or Gleinalm toll stations on the A9 (see section 2.2.2 "Open toll lane operation on A9") without having paid the toll properly.
- The driver of a motor vehicle with a maximum permissible total weight up to and including 3.5t (category 1) uses a toll road although the Digital Route Toll Flex service is blocked for the license plate of the motor vehicle and the driver does not pay the toll properly in any other way.

7.2 NON-IMPOSITION OF A PENALTY

A penalty is not imposed if a substitute toll - as described below (item 7.3) - is paid. Any substitute toll duly paid in accordance with § 19 BStMG cannot be reclaimed (§ 20 para. 6 BStMG).

7.3 SUBSTITUTE TOLL

7.3.1 Method of payment

The substitute toll may not be paid in instalments. If instalments are received, they will be credited to the payer's account minus a processing fee of €15.00 (including 20% VAT). This also applies to late payments, payments without stating the correct identification number or invoice number, as well as payments to an account other than the one disclosed on the copy of the request for payment of the substitute toll or the information letter in accordance with section 30b para. 1 BStMG. In the

event of overpayment by less than €5.00, no money will be credited to the payer's account (otherwise the entire amount will be credited to the payer's account).

7.3.1.1 Request by toll enforcement officers

Toll enforcement officers are authorized to verbally request the motor vehicle driver (if necessary also as representative of the license holder in accordance with § 19 para. 5 BStMG) to pay a substitute toll. The substitute toll shall be paid immediately upon request by the toll enforcement officer in cash or by the payment method specified in Appendix 2. The vehicle driver shall be issued with a confirmation of the payment made.

7.3.1.2 Retroactive summons procedure

If a violation is discovered by means of automatic checks without the driver being apprehended in person, the/a holder of the registration certificate may receive a written request to pay the substitute toll.

In cross-border procedures, the request for payment of the substitute toll is made in the form of an information letter in accordance with section 30b para. 1 of the BStMG, which is listed as a model in Appendix 8 to the tolling regulations.

In addition to the amount of the substitute toll to be paid, the written request shall contain, among other things, an identification number or an invoice number and the claimant's bank details.

The substitute toll must be transferred to the account specified in the request for payment or the information letter in accordance with section 30b para. 1 BStMG, stating the identification number or invoice number specified in the request. The request for payment of the substitute toll is complied with if it is credited to the specified account within two weeks of the deposit and the transfer order contains the correct, complete and automatically readable identification number (or invoice number).

7.3.2 Substitute toll rate

The substitute toll rates (including 20% VAT) for non-payment of the required toll are given below:

Vehicle category	Substitute toll rate
A (i.e. single-track vehicles)	€ 65.00
B (i.e. twin-track vehicles with an MPW of up to 3.5 t)	€ 120.00

If the re-registration of the digital annual card has been omitted before using a section toll segment with the motor vehicle liable to pay the toll, the following applies:

If it is established that the toll has not been properly paid and the driver of the motor vehicle is requested in writing by toll supervisory authorities or the holder of the registration certificate is requested in writing by ASFINAG to pay the substitute toll, the driver/holder of the registration certificate may contact the ASFINAG Service Center after receiving the request to pay a substitute toll or an information letter in accordance with section 30b para. 1 BStMG and the ASFINAG Service Center will re-register the vehicle to the newly registered license plate number, provided

that the conditions for re-registering the digital annual card as per item 4.8 are met and appropriate evidence is presented.

In this case, upon proper payment of a replacement toll, the road toll for the used toll section for that license plate number which was newly assigned to the holder of the registration certificate shall be paid retroactively for the period between the day of the first administrative offence with the newly assigned license plate number and the day of the re-registration. In this case, the amount of EUR 18 for the re-registration (see point 4.8) is not payable or will be refunded.

If a digital annual card has been obtained by means of distance selling as a consumer and the section toll segment has been used before the 18th day after obtainment (for the earliest possible start of validity see section 4.2), the following applies:

If it is established that the toll has not been properly paid and the driver of the motor vehicle is requested in writing to pay the substitute toll by toll enforcement officers or the holder of the registration certificate by ASFINAG, the driver of the motor vehicle/holder of the registration certificate may, after receiving the request to pay a substitute toll or an information letter in accordance with section 30b para. 1 BStMG, may contact the ASFINAG Service Center and invoke the fact that the section toll segment with the licence plate number concerned was used in the period between the purchase of the digital annual card and the 18th day after obtainment (earliest possible start of validity). In this case, upon proper payment of a substitute toll, the section toll for the used section toll for this period shall be paid retroactively.

If the use of a section toll segment by a vehicle with an obligation to pay tolls is established several times within 30 days without the toll having been duly paid, ASFINAG will issue requests for payment of a substitute toll or send information letters in accordance with section 30b para. 1 BStMG for a maximum of three cases of toll evasion. For any cases of toll evasion on the same toll section exceeding this amount, no substitute toll is payable and these cases will not be reported to the district administrative authority.

Temporary arrangements for the A9 toll section up to and including 31.12.2022

If the open lane of the Bosruck and/or Gleinalm toll stations on the A9 motorway has been used without having properly paid the toll, an administrative offence has been committed.

Up to and including 31.12.2022, the toll for motor vehicles whose registration number was not properly registered in the toll system for the Bosruck/Gleinalm section of the A9 motorway at the time of use of the open lane at the toll stations on the A9 motorway (hereinafter "improper passage") shall be deemed to have been duly paid retroactively in the following cases

- If a single trip ticket is purchased on the day of the improper passage or on the two following calendar days and the purchaser contacts the ASFINAG Service Center or the toll stations Bosruck or Gleinalm within this period, the latter will subsequently credit the subsequently purchased single trip ticket against the improper passage, whereby the toll is deemed to have been paid retroactively. Once the single trip ticket has been credited, it no longer entitles the holder to use the road toll section. If the open lane was not used properly several times on a calendar day, a single trip ticket must be purchased for each passage. The process described above applies accordingly.
- If an annual ticket for the used marker for the A9 motorway toll section has not been extended, an annual ticket for the A9 motorway toll section for this marker can be purchased

retrospectively as an alternative to retrospective payment by way of a subsequent purchase of a single trip ticket. The purchaser must contact the ASFINAG Service Center or the toll stations in Bosruck or Gleinalm and they will (even if a request for payment of a replacement toll has already been made) date the retroactively purchased annual pass to the day following the expiry date of the previous annual pass, provided that the day of the improper passage is no longer than one year after the expiry date of the previous annual pass. In this case too, the toll is considered to be paid retroactively.

7.3.3 Continued journey

The payment of the substitute toll entitles to use the (incorrectly paid) toll road on the day of entering or checking the road by the toll enforcement officers, on the day of the administrative violation detected by automatic monitoring and on the following calendar day.

The receipt issued by the toll inspectorate shall be considered as proof of payment of the substitute toll; however, if the substitute toll is not paid despite a request for payment when the toll inspectorate enters or inspects the road section, the road section (regardless of the further course of the toll road) shall be left immediately via the next possible exit.

In the event of non-compliance, the offence of toll evasion shall be committed.

7.3.4 Payment of the substitute toll

Substitute tolls must be paid in euros. Information regarding the means and methods of payment that are accepted for payment of the substitute toll to toll enforcement officers is given in Appendix 2 as well as on the Internet at www.asfinag.at respectively by the ASFINAG Service Center.

8 VIOLATION OF THE OBLIGATION TO STOP

Drivers who, contrary to section 18(2) BStMG, do not stop when requested to do so by an officer defined in section 9 are in breach of an administrative rule according to section 21 BStMG and must be fined up to €3,000.00.

PART B: TOLLING REGULATIONS FOR TWIN-TRACK VEHICLES WITH A MAXIMUM TOTAL WEIGHT OF MORE THAN 3.5 T

1 GENERAL INFORMATION

The distance-related toll is collected using a fully electronic toll system.

The entire road network subject to tolls is divided into individual toll sections, with the toll being collected separately for each individual toll section. The distance-related toll serves the surcharges of the infrastructure costs as well as the costs for traffic-related air and noise pollution.

To ensure correct payment of the toll, an authorised, correctly functioning, and permanently and properly attached on-board unit (a GO-Box or a Split GO-Box, both hereinafter referred to as 'GO-Box'—see section 5.7.1 of Tolling Regulations Part B—or another authorised on-board unit—see section C) must be carried in the vehicle that is liable for the toll. In principle, steel structures (so-called toll collection points or toll gantries—see figure 13) fitted with antenna (radio beacons) are installed over the carriageway between the individual junctions on the road network subject to tolls.



Figure 13

When a vehicle passes a toll collection point, the on-board unit in the vehicle communicates with the toll collection point's antenna over the road by means of microwave technology and consequently initiates toll collection (also referred to as a toll transaction or toll charging).

In accordance with section 7.3, ASFINAG reserves the right to bill users retroactively and automatically for the toll that must be paid on specific toll sections without necessarily erecting a toll collection point on that specific toll section. The toll section rates that apply to these sections are listed according to category and toll rate group in Appendix 4.

In accordance with section 4 of the Federal Road Tolls Act 2002 as amended (BStMG), drivers and holders of registration certificates (both hereinafter referred to as 'customer') are jointly liable to pay the toll.

In the following, the term "customer" applies to the holder of the registration certificate, the driver or a third party attributable to the holder of the registration certificate (for example a dispatcher, secretary or fleet manager).

2 SCOPE OF APPLICATION

Tolling Regulations Part B applies to all twin-track vehicles with a maximum total weight of more than 3.5 t. These vehicles are liable for a distance-related toll.

For multi-lane motor vehicles that have never been registered for traffic and carry test drive or transfer license plates, distance-related tolls apply, provided their tare weight exceeds 3.5 t. In the

case of journeys with test drive or transfer licence plates, a copy of the type certificate or a confirmation of the producer or their authorised representative in accordance with § 29 para. 2 KFG about the tare weight of the motor vehicle must be carried along, which must be presented upon request. If evidence of this kind cannot be presented on request, the twin-track vehicle in question shall be considered a vehicle with a service weight of more than 3.5 t.

No toll must be paid for trailers being towed by twin-track vehicles with a maximum total weight of up to 3.5 t.

3 TOLL OBLIGATION

3.1 Road network subject to tolls

Distance-related tolls must be paid for vehicles that are liable for the toll for use of the motorways and expressways listed and illustrated below:



Figure 14

Toll roads in Vienna:



Figure 15

In accordance with the Toll Section Exemption Ordinance issued by the Federal Minister for Transport, Innovation, and Technology, BGBl. II. No. 204/2010 as amended, the following sections of motorway or expressway are excluded from the mandatory distance-related toll system:

- the section of the S 5 Stockerauer expressway between the Jettsdorf intersection (S 33) and the Krems junction (regional highway B 3, regional highway B 37).

3.1.1 Areas with existing road tolls

The distance-related toll also applies for the use of the motorways and expressways with existing toll stations (A 9, A 10, A 11, A 13, and S 16). It is no longer possible to pay the toll for vehicles with a maximum total weight of more than 3.5 t manually at existing toll booths.

Vehicles may only drive through existing main toll stations on the specially marked lanes. Depending on traffic volume, so-called open toll lane operation or mixed toll lane operation may be used on these lanes.

3.1.1.1 Mixed toll lane operation

During mixed lane operation, the toll lane may be used by both vehicles with a maximum total weight of up to 3.5 t (see Tolling Regulations Part A II) and vehicles with a maximum total weight of more than 3.5 t (see corresponding signs in figure 16a below). The barrier used for mixed toll lane operation is automatically raised for vehicles with a maximum total weight of more than 3.5 t if the distance-related toll has been correctly paid. If this is not the case, the barrier remains down. In this case, instructions given by the toll station personnel must be followed. All lanes at secondary toll stations are mixed toll lanes. This means that there are no special toll lane operation signs at the secondary toll stations at the Zederhaus and St. Michael/Lungau junctions on the A 10 and the Zenzenhof, Igls Patsch, Schönberg Stubaital, Matrei Steinach, Nösslach, and Brennersee junctions on the A 13.

3.1.1.2 Open toll lane operation on A10, A11, A13 and S16

In open toll lane operation on the A10, A11, A13 and S16, one lane is only permitted for motor vehicles subject to distance-related tolls. These lanes will be clearly marked as such (see figure 16b).

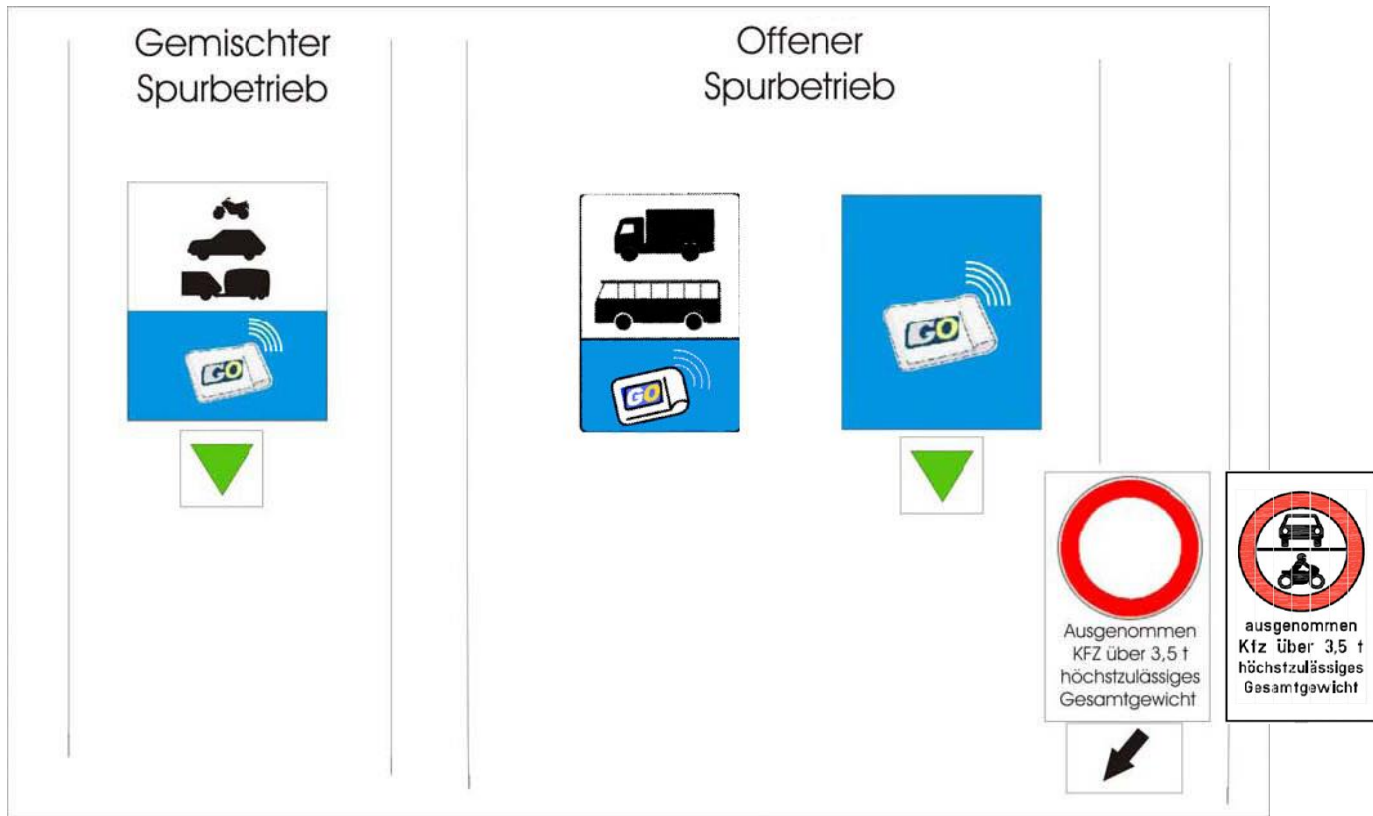

Figure 16a "Mixed toll lane operation"

Figure 16b "Open toll lane operation on A10, A11, A13 and S16"

In open toll lane operation, motor vehicles with a maximum permissible total weight of up to and including 3.5t (category 1) are prohibited from driving in accordance with the StVO. Drivers who violate this prohibition are in breach of an administrative rule (see Part A II, section 6).

3.1.1.3 Open toll lane operation on A 9

In open toll lane operation at the toll stations on the A9 (Bosruck, Gleinalm), at least one lane is also open for vehicles subject to distance-related tolls. This is specially marked (see Figure 16c).

Like the open lane operation on the A10, A11, A13 and S16, open lane operation at the toll stations on the A9 (Bosruck/Gleinalm) is conducted without barriers, but with the difference that open lane operation on the A9 is also permitted for motor vehicles with a maximum permissible total weight of up to and including 3.5 t whose license plates have a valid digital section toll authorisation for the Bosruck/Gleinalm toll section (see Part A II Item 1.1., 1.3.1) or for which digital section toll Flex has been enabled (see Part A II item 4.2.2).



Figure 16c "Open toll lane operation on A9".

3.1.2 The toll obligation in areas around road works

The toll obligation must be paid in full for areas around road works. The toll obligation must also be paid in full for road works that require traffic to use different lanes or carriageways, or on sections where contraflow systems have been introduced. Vehicles travelling to or from the works area are also liable to pay the toll.

Only trips made on the carriageways that are closed to traffic are an exception to this rule. This exemption requires that the vehicle that is liable for the toll is correctly registered with the system in accordance with section 5, and that the GO-Box in the vehicle (both for the prepaid and post-pay procedures) is deactivated, for example by properly attaching the shield cover that is available from ASFINAG Maut Service GmbH at GO points of sale (see section 5.3). To this end, the cover must be wrapped at least three times around the GO-Box and subsequently closed securely using staples or adhesive tape. If the GO-Box is not disabled, the system will cause a toll transaction or toll debit. If this happens, the collected tolls will not be refunded.

3.1.3 Temporary entries and exits in accordance with section 26(2) Federal Highways Act

The existence of entries and exits in accordance with section 26(2) of the Federal Highways Act 1971 (i.e. temporary entries and exits from the road network subject to tolls in conjunction with infrastructure projects that are being carried out in the public interest) does not affect in any way the toll sections and toll section rates. Depending on the location of the toll collection station on the one hand and the entries and exits created within a toll section on the other, the toll section rate must be paid in full if the vehicle passes a toll collection station that is used to collect the rate for that toll section, even if only part of the toll section is used.

3.2 Signing

Information signs on federal and regional highways leading to border crossings for motor vehicle traffic notify road users of the toll obligation (see figures 17 and 18 below). Road users are also notified of the toll obligation on additional information signs on all approach roads leading to motorways and expressways on which tolls are levied (see figure 19 below).



Figure 17*



Figure 18*



Figure 19*

(*)The toll sticker (vignette) symbol refers to the toll for which vehicles with a maximum total weight of up to 3.5 t are liable, see Tolling Regulations Part A I for details

3.3 Exemptions from the toll obligation

3.3.1 Permanent exemptions

The following vehicles are exempt from the toll obligation:

- Vehicles with visible blue headlights or warning lights in accordance with section 20(1)(4) and (5) of the Motor Traffic Act 1967 (hereinafter referred to as 'KFG' for short). In the case of motor vehicles pursuant to § 20 para. 5 KFG, an exemption from the toll obligation exists only for the duration of the use of the headlamp or warning light with blue light and if the conditions and requirements issued pursuant to § 20 para. 6 KFG are complied with during use. The return journey from an operation in which headlights or warning lights with blue light were used is also exempt from the toll obligation.
- Vehicles with visible blue headlights or warning lights in accordance with section 20(5) of the KFG and registered in the name of non-profit institutions, the tasks of which are fulfilled mainly by voluntary workers. The regular use of motor vehicles for the purposes of these devices (or of a device mentioned in § 20 para. 1 Z 4 KFG) shall be deemed equivalent to a licence if headlamps or warning lights with blue light are visibly attached to the motor vehicles in accordance with § 20 para. 5 KFG. The respective institution must prove to ASFINAG by 30 September of each year for the following year by means of a written application and provide appropriate evidence that the conditions laid down in this provision are fulfilled and for which motor vehicles the exemption is applied for.
- Motor vehicles of fire brigade associations to which headlights or warning lights with blue light are visibly attached in accordance with § 20 para. 5 KFG.

- Army vehicles (section 2(1)(38) Motor Traffic Act 1967).
- Motor vehicles which are subject to the agreement between the states which are parties to the North Atlantic Treaty and the other states participating in the Partnership for Peace on the legal status of their troops ("PfP-SOFA", BGBl. III No. 136/1998). If non-military vehicles are used for these journeys, such vehicles shall be provisionally subject to the provisions of distance-related tolls. The toll paid in the course of these trips will be refunded by ASFINAG free of charge. The request for reimbursement must be submitted by the respective competent state authority directly to ASFINAG Maut Service GmbH (see Appendix 7b) after completion of the journeys, together with the relevant evidence.
- Vehicles that are used for the implementation of measures for securing peace within the scope of an international organisation, the Organisation for Security and Co-operation in Europe, or the European Union in conformity with a Decision made within the scope of the Common Foreign and Security Policy. If non-military vehicles are used on these journeys, these vehicles will be subject to the provisions of distance-related tolls for the time being. The toll paid in the course of these trips will be refunded by ASFINAG free of charge. Applications for refunds must be submitted by the relevant state authorities once the trips have been completed. Refund applications must be accompanied by evidence that the toll was paid and submitted directly to ASFINAG Maut Service GmbH (see section 14).
- Vehicles belonging to the public security forces, tax authorities, prison services, and foreign security forces in accordance with section 2(3) of the Police Cooperation Act (Polizeikooperationsgesetz), as well as vehicles belonging to foreign customs and judicial authorities. Confiscated vehicles that use the road network subject to tolls and to which an official tax authority registration number has been attached are not liable for the toll.
- Vehicles belonging to foreign public emergency services, foreign fire brigades or foreign rescue services. Such motor vehicles shall be exempt from the obligation to pay tolls only if they are fitted with headlamps or warning lights emitting a blue light visibly on the outside and only for the duration of the use of the headlamp or warning light emitting a blue light. The return journey from an operation in which headlights or warning lights with blue light were used is also exempt from the toll obligation.

Vehicles that have blue headlights or warning lights visibly attached to the exterior, but are not registered and therefore carry transfer license plates or other equivalent plates and that use the road network subject to tolls are not exempt from the toll obligation.

3.3.2 Temporary exceptions

3.3.2.1 Exceptions for humanitarian aid transports

In addition to the above provision, ASFINAG may in accordance with section 5(2) BStMG and depending on the circumstances, exempt vehicles with a maximum total weight of more than 3.5 t that are delivering humanitarian aid in the event of emergencies or disasters from the toll obligation. To obtain such an exemption, which allows a trip to be completed without payment of the toll (i.e. no GO-Box or other authorised on-board unit must be fitted in the vehicle), an exemption application form (see Appendix 3b) must be completed on the INTERNET at www.go-maut.at and subsequently printed out at least 30 minutes before use of the road network subject to tolls. The completed, printed form must then be duly signed. If no Internet connection is available, the

applicant must call the ASFINAG SERVICE CENTER (the telephone number is given in section 14 and in the information in section 14). The application form will then be completed by the ASFINAG SERVICE CENTER agent in accordance with the details provided by the applicant and then faxed to the applicant. This fax must then be duly signed. Each application has a specific application number and is only valid for a freely selectable calendar day. In the event of national disasters, ASFINAG reserves the right to grant an exemption from the toll obligation for a period of more than one day. The fully completed and signed application form (original) must be carried in the vehicle for the duration of the trip that is exempt from the toll obligation and must be presented on request as evidence of exemption approval. Before starting the journey, the applicant is obliged to request the activation of the exemption from the toll obligation. To this end, the applicant should call the ASFINAG SERVICE CENTER (the telephone number can be found in section 5.3 and the information in section 14) and provide the registration number of the vehicle and the specific application number.

If the vehicle in question is fitted with a GO-Box or another authorised on-board unit, the following provisions must be observed: Exemption from the payment of the toll requires that the GO-Box used for the prepaid procedure (see sections 5.5.1 and 5.5.3) is deactivated by the customer for the duration of the trip that is exempt from the toll obligation, for example by properly attaching the shield cover that is available from ASFINAG Maut Service GmbH at GO points of sale (see sections 5.3). To this end, the cover must be wrapped at least three times around the GO-Box and subsequently closed securely using staples or adhesive tape.

If the GO-Box for prepaid procedures is not deactivated, toll transactions will be triggered or tolls collected automatically. In such a case, the reimbursement of the amounts charged is excluded. These instructions do not apply to GO-Boxes that are used for the post-pay procedure or other authorised on-board units (see sections 5.5.1 and 5.5.2). Consequently, the GO-Box must not be deactivated and may remain in the vehicle. This provision applies exclusively to those cases that result from a cause within the meaning of section 5(2) of the Federal Road Tolls Act and which is announced at this point in the Tolling Regulations.

3.3.2.2 Exceptions at the request of the Federal Ministry of the Interior (BM.I) in the context of state crisis and disaster control management or international disaster aid

At the request of the Federal Ministry of the Interior (BM.I), journeys made by motor vehicles with a maximum permissible total weight of more than 3.5 t within the context of state crises and disaster management or international disaster relief may be exempted from payment of the toll on specific occasions.

To enable such trips to be made without the obligation to pay the toll (it is not necessary to equip the motor vehicle with a GO-Box or another approved vehicle device), the Federal Ministry of the Interior (BM.I) must notify ASFINAG of these trips, listing the license plate number of the motor vehicles concerned and announcing the expected route and the exemption period before using the road network subject to toll payment.

The written confirmation of the Federal Ministry of the Interior (BM.I) concerning the concrete exception to the toll duty during the toll-free trip must be carried in the affected motor vehicles and presented on request as proof of entitlement.

If a GO-Box or another approved vehicle device is carried, the following must be observed: Exemption from the payment of the toll requires that the GO-Box used for the prepaid procedure

(see sections 5.5.1 and 5.5.3) is deactivated by the customer for the duration of the trip that is exempt from the toll obligation, for example by properly attaching the shield cover that is available from ASFINAG Maut Service GmbH at GO points of sale (see section 5.3). To this end, the cover must be wrapped at least three times around the GO-Box and subsequently closed securely using staples or adhesive tape.

If the GO-Box is not disabled, the system will cause a toll transaction or toll debit. In such a case, the reimbursement of the amounts charged is excluded.

3.3.3 Special exemptions

Vehicles that are towed away are exempt from the distance-related toll for the duration of the towing procedure. Neither the axles of the vehicle being towed away, nor the axles of any attached trailers or motorhomes that also have to be towed away increase the category that must be set for the towing vehicle. This exemption requires that the GO-Box in the vehicle being towed away (both for the prepaid and post-pay procedures) is deactivated, for example by properly attaching the shield cover that is available from ASFINAG Maut Service GmbH at GO points of sale (see section 5.3). To this end, the cover must be wrapped at least three times around the GO-Box and subsequently closed securely using staples or adhesive tape. If the GO-Box is not disabled, the system will cause a toll transaction or toll debit. If this happens, the collected tolls will not be refunded.

Please note that in accordance with section 46(3) StVO 1960, the vehicle being towed away must leave the motorway or expressway immediately at the next exit (junction).

4 TOLL TARIFFS

The toll rates are based on the Federal Road Tolls Act 2002 as well as the relevant Toll Rate Ordinance (Mauttarifverordnung). Based on these provisions the Tolling Regulations sets in Appendix 4 (toll section rate charts) for each toll section the actual valid toll rates per road section for the overall costs as well as the costs for traffic-related air and noise pollution. These calculated toll rates per road section are listed without VAT.

To read the toll rates per road section charts more easily, each toll section is named after the junction respectively intersection according to the signs on those roads on which toll is being charged. The toll rates per road section stay the same in case of road works, temporary relocations or other time related bans of junctions.

In the post-pay procedure, the net toll tariffs are added up daily for each vehicle registration number and for each means of payment deposited (daily total). Based on the daily sum the VAT will be calculated and added which results in the gross-toll rate for the day. For the prepaid contracts the VAT will be paid when charging the toll amount on the device.

The EURO emission class is a characteristic of the vehicle and is determined – on the basis of EU directives – by the limit values for emissions. Decisive for the deposit of a EURO emission class is the compliance with emission limits of the engine installed in the vehicle.

In accordance with the valid version of the Toll Rate Ordinance, the following toll rate groups in order to surcharge for infrastructure apply:

TOLL RATE GROUP	MOTOR VEHICLES
E	POWERED PURELY BY ELECTRIC OR HYDROGEN FUEL CELL
A	EURO EMISSION CLASS VI
B	EURO EMISSION CLASS 0 to EEV

The following toll rate groups for equating traffic-related air pollution are stipulated in the current Toll Rate Ordinance:

TOLL RATE GROUP	MOTOR VEHICLES
A	EURO EMISSION CLASS VI
B	EURO EMISSION CLASSES EURO V and EEV
C	EURO EMISSION CLASS IV
D	EURO EMISSION CLASSES 0-III

The basic kilometre rate for traffic-related noise pollution will be differentiated by time (day/night). The “night” rate is defined by the time period between 10 pm and 5 am. The time registered in the toll system at the time the vehicle passes the appropriate toll collection point is decisive when it comes to determining whether the night-time rate applies (the time on the radio-controlled clock is used as a reference).

According to the Toll Rate Ordinance the basic kilometre rate for surcharges concerning traffic-related air pollution and traffic-related noise pollution is not valid on the road A 12 between the national border Kufstein and the Innsbruck/Amras intersection (A 13) as well as the whole A 13 motorway.

If a vehicle that was classified before 3 January 2009 does not have EURO I-VI classification, the following concordance table applies.

EURO I	Euro 1
EURO II	Euro 2
EURO III	Euro 3
EURO IV	Euro 4
EURO V	Euro 5
EURO VI	Euro 6

Concerning the differentiation of toll rates due to the number of axles the following applies:

The number of axles must include attached lift axles, tandem axles and double axles. Support axles and trailers that are attached to buses or motor caravans as described in section 2(1) (28a) of the Motor Traffic Act 1967, on the other hand, must not be taken into account when counting the number of axles.

The toll rates for the toll sections mentioned in section 10 (2) BStMG are also based on the Toll Rate Ordinance as well as section 9 BStMG.

Holders of registration certificates of vehicles in category 4, to which the night-time rate on the A 13 does not apply, but for which a toll is collected for technical reasons, may apply to have the difference between the night-time rate and the normal rate refunded within six months of travelling on the toll section in question (see Appendix 6). The application form is available at the main toll station in Schönberg and on the ASFINAG website at www.asfinag.at.

The following documents must be submitted with the first application:

- information concerning the toll section used and the time of passage (itemised toll information sheets or transaction information, i.e. the information about the last 30 transactions stored in the GO-Box, at GO points of sale)
- Copy of the vehicle registration certificate
- name of account holder and bank account details for the transfer of the refunded amount.

As long as there is no change in the aforementioned data, only the toll section used and the time of passage must be indicated when submitting further refund applications for the same vehicle. Applications for refunds must be submitted by post or fax to ASFINAG Maut Service GmbH (see section 14).

If the toll for the trip is paid using the prepaid procedure, the driver of the vehicle must ensure that there is enough toll credit in the GO-Box to cover the toll. Partial non-payment of the toll resulting from insufficient toll credit in the GO-Box shall be treated as a toll evasion offence and incurs all the relevant consequences and penalties.

5 REGISTERING WITH AND DEREGISTERING FROM THE TOLL SYSTEM

5.1 General information

In accordance with section 8(1) BStMG, the drivers of vehicles that are liable for the toll are obliged to equip their vehicles with authorised on-board units for electronic collection of the distance-related toll in accordance with the provisions of Tolling Regulations before using the road network subject to tolls.

This obligation includes

- registering with the toll system (system registration for the post-pay or prepaid procedure; see section 5.5),
- the acquisition of an approved vehicle device and
- and the permanent, proper attachment of this unit to the vehicle that is liable for the toll (see section 8.1).

There are no plans for other forms of toll collection. Retroactive payment of the toll is only possible in certain circumstances (see sections 7.1 and/or 7.2). The vehicle registration certificate for the vehicle that is liable for the toll must be presented for registration with the toll system.

Only the following on-board units are authorised for electronic toll collection:

- ASFINAG on-board units: the GO-Box or the Split-GO-Box (see point 5.7)
- On-board units that have been specifically authorised by the operators of foreign toll systems (see section C). Motor traders using an authorised on-board unit are not subject to the special provisions in section 5.6.6).

5.2 Declaration of the relevant EURO emission class

As a rule, vehicles are allocated in each case to the highest toll rate group and the EURO emission class I is entered in the central system and on the GO-Box for the relevant vehicle registration number, unless the driver has requested or requests the entry of a better EURO emission class (hereinafter referred to as the 'requested EURO emission class'). For motor vehicles with a EURO emission class up to EURO III, a declaration at the GO point of sale or proof of the EURO emission class is not required.

A specific EURO emission class must be explicitly requested at a GO point of sale not only when declaring the EURO emission class, but also when registering for the toll system or when changing data (see point 5.6). For this purpose, it is necessary to present the GO-Box at the GO point of sale.

The legality of the saving of the required EURO emission class is not checked at the GO point of sale. Proof of the legality of the required EURO emission class is therefore not required at the GO-POINT OF SALE. ASFINAG must be provided with documents that provide evidence of the legitimacy of the requested EURO emission class either in advance (see section 5.2.2.2) or at a later date (see section 5.2.2.1). The expressly requested EURO emission class is stored at the GO-POINT OF SALE on the GO-Box and in the central system and is thus directly relevant to the rate.

A claim to the toll rate assigned to the respective toll rate group only arises when the EURO emission class has been stored on the GO-Box at the GO point of sale and the verification process (proof of the legality of the requested EURO emission class) has been completed positively. Refer to section 5.2.2 with regards the deadline for evidence.

After the required EURO emission class has been saved at the GO point of sale, a vehicle declaration will be handed out, which exhibits

- the requested and stored EURO emission class
- the official vehicle registration number stored in the GO-Box and
- the GO-Box identification number stored on the GO-Box

This vehicle declaration must always remain in the vehicle.

A customer receipt of the stored vehicle date is also issued when the EURO emission class is entered. This contains the following information:

- the vehicle registration number concerned and the GO-Box identification number,
- the date and time of the EURO emission class entered at this time and
- deadlines to be observed by the holder of the registration certificate, where applicable.

The requested EURO emission class is instantly visible

- on itemised toll information sheets (section 6),
- other printouts from a GO point of sale as well as
- in the SelfCare Portal

5.2.1 Declaration of the EURO emission class

5.2.1.1 Declaration of the EURO emission class by the holder of the registration certificate

For the purpose of declaring the EURO emission class, the holder of the registration certificate themselves may request the saving of a specific EURO emission class on site at a GO point of sale.

After the EURO emission class has been saved at a GO point of sale, the vehicle declaration is issued. By checking the vehicle declaration which has been issued, the holder of the registration certificate is to ensure that

- the official vehicle registration number stored in the GO-Box is the same as the actual vehicle registration number attached to the vehicle and
- the GO-Box identification number of the GO-Box carried corresponds to the GO-Box identification number stated on the vehicle declaration and
- the requested EURO emission class was stored according to the declaration of the holder of the registration certificate.

If the holder of the registration certificate notices any discrepancies, they must request that the information be corrected immediately at the GO point of sale. Failure to comply with this provision constitutes a toll evasion offence in accordance with section 10. This obligation to check also applies to reprints or when a new vehicle declaration is being issued. Generally, the vehicle declaration is to be carried by the driver during the trip (see section 8).

In addition, an information document is handed over, which is also subject to an obligation to check by the holder of the registration certificate.

5.2.1.2 Declaration of the EURO emission class by a third party designated by the holder of the registration certificate

The holder of the registration certificate is entitled to instruct a third party (in particular the driver of the vehicle) to request the saving of a specific EURO emission class on site at a GO point of sale. In this case, the third party acts as a representative of the holder of the registration certificate and takes over the declaration of the EURO emission class for them.

After the EURO emission class has been saved at a GO point of sale, the vehicle declaration will also be issued in this case. The third party is to check the vehicle declaration, in order to ensure that

- the official vehicle registration number stored in the GO-Box is the same as the actual vehicle registration number attached to the vehicle and
- the GO-Box identification number of the GO-Box carried corresponds to the GO-Box identification number stated on the vehicle declaration and
- that the EURO emission class given to the third party by the holder of the registration certificate was stored accordingly.

If the third party notices any discrepancies, they must request that the information be corrected immediately at the GO point of sale. Failure to comply with this provision constitutes a toll evasion offence in accordance with section 10. This obligation to check also applies to reprints or when a new vehicle declaration is being issued. Generally, the vehicle declaration is to be carried by the driver during the trip (see section 8).

The holder of the registration certificate is responsible for the correctness of the EURO emission class declaration. To this end, the holder of the registration certificate is to promptly request that the third party hands over the customer receipt to the holder of the registration certificate in order to ensure that the required evidence can be provided in time (see section 5.2.2.).

If the holder of the registration certificate discovers after handing over the information document that an incorrect EURO emission class has been saved, the holder of the registration certificate must immediately save the correct EURO emission class at a GO point of sale or have it saved by a third party. Express reference is made to the possibility of retroactive toll payment in accordance with section 7. Refunds will not be given for excess toll payments made in the period before the new EURO emission class is entered.

5.2.2 Checking the requested EURO emission class/allocation to a toll rate group (verification)

If the entry of a EURO emission class is requested, ASFINAG must be provided with evidence of the legitimacy of the requested and entered EURO emission class in the form of suitable documents (see section 5.2.3).

The holder of the registration certificate will be informed of the obligation to provide such evidence in the form of a customer receipt that will be given to the holder of the registration certificate at the GO point of sale in German and, if available, in the national language of the country in which the vehicle is registered. If the EURO emission class is saved at the GO point of sale by a third party designated by the holder of the registration certificate, the third party must hand over the information document to the holder of the registration certificate or the holder of the registration certificate is obliged to request this information document from the third party.

If the requested EURO emission class is allocated to the toll rate groups for which in each case the highest rate has been set (hereinafter referred to as the 'highest toll rate groups'), it is not necessary to provide evidence. This is the rule for the EURO emission classes up to and including EURO III. The omission of the provision of proof is also indicated by a corresponding information document, which is handed over at the GO point of sale in German and – if available – in the national language of the country of registration of the vehicle registration plate, otherwise in English.

The provision of evidence for the required EURO emission class, which are not allocated to the highest toll rate groups, can take place

- subsequently, after the EURO emission class has been entered at the GO point of sale (for information on subsequent verification, see section 5.2.2.1) or
- in advance before depositing at the GO point of sale (verification process in advance, see item 5.2.2.2).

This is the case for the EURO emission classes IV, V, EEV and VI, as for those classes, confirmation documents are required.

5.2.2.1 Subsequent verification

The verification process is not carried out on site at the GO point of sale but centrally by ASFINAG. The necessary documents (see section 5.2.3) must be sent to ASFINAG. There are a number of possible ways of doing so:

a) by post

In this case, the documents must be sent to the following postal address:

ASFINAG Maut Service GmbH
z.H. ASFINAG SERVICE CENTER/emission classes
Alpenstraße 99
A-5020 Salzburg, Austria

b) by fax

In this case, the documents must be sent to the following fax number:

ASFINAG Maut Service GmbH
z.H. ASFINAG SERVICE CENTER/emission classes
+43 / 50108 912913

c) by e-mail

The necessary documents may be sent as

- pdf
- jpg
- tif

files to euroclass@asfinag.at for verification.

The necessary documents sent by e-mail are considered sent when receipt of the e-mail is confirmed in the form of a response e-mail from ASFINAG to the sender.

d) via the SelfCare portal

All registered SelfCare users have the option of submitting the following documents for their vehicles (vehicle license plates registered for the toll system)

to the following address www.go-maut.at for verification.

The necessary verification documents may be sent in the following formats:

- pdf
- jpg
- tif

be transmitted.

The verification documents required for the verification process must be submitted to ASFINAG within **28 calendar days** (date of receipt), calculated from the date of saving of the required EURO emission class at a GO point of sale (hereinafter referred to as the "**submission deadline**").

To facilitate the process, ASFINAG has prepared an application form that must be filled out and submitted with the documents. This application form, which is available in a variety of languages,

- can be downloaded from
 - via the SelfCare Portal (www.go-maut.at) or
 - via www.asfinag.at
- can be requested from the ASFINAG SERVICE CENTER.

It is not possible to transmit the evidence directly from the GO point of sale.

If the necessary documents are sent to ASFINAG before the submission deadline, ASFINAG will begin verification of the documents as soon as they arrive.

5.2.2.1.1 Complete, legible, and timely submission of the suitable documents

If the requested and entered EURO emission class can be verified on the basis of the submitted documents, the verification procedure is concluded with a positive outcome. This positive outcome can be viewed in the SelfCare portal. Furthermore it is possible to ask the ASFINAG SERVICE CENTER for information about the processing status and outcome of the verification process. In the event of a positive outcome, there is legal certainty about the requested and entered EURO emission class.

5.2.2.1.2 Incomplete and/or faulty documents that have been submitted before the submission deadline

If the necessary documents are sent to ASFINAG before the submission deadline, but are found to be faulty (e.g. illegible) or incomplete, ASFINAG will request the driver once only to re-submit the missing and/or incomplete documents.

In order to make it possible for ASFINAG to send such queries or requests, it is essential that the driver provides a valid contact address on the application form.

If it is possible to make a request for re-submission, the submission deadline for submission of the missing and/or incomplete documents is extended once by seven days to a maximum total of 35 calendar days.

If, after ASFINAG's request for re-submission, the necessary documents are submitted properly and in time and if the legitimacy of the requested and entered EURO emission class can be verified, the verification procedure is concluded with a positive outcome. The provisions of section 5.2.2.1.1 shall apply accordingly.

If ASFINAG's request for re-submission is only partially met or not met at all, the verification process is concluded with a negative outcome. In this case, the provisions of section 5.2.2.1.4 shall apply accordingly.

If no valid contact address is provided, the verification process is concluded with a negative outcome. In this case, the provisions of section 5.2.2.1.4 shall apply accordingly.

5.2.2.1.3 Timely registration of verification documents for an incorrect EURO emission class

If verification documents are transmitted within the registration period which prove that an incorrect EURO emission class was requested and deposited at a GO point of sale, a differentiation must be made as follows:

a) Allocation of the EURO emission class on the basis of the submitted documents to a toll rate group that results in the payment of a lower toll rate

In this case, the EURO emission class determined by the verification of the submitted documents will be entered in the central system.

Two brief acoustic signals (see section 8.2.4.3.1) alert the driver to the fact that they must go to a GO point of sale to change the EURO emission class stored in the system for their vehicle.

If no GO point of sale is visited despite signalling, the GO-Box is subsequently actively disabled, whereby this disabling is announced to the motor vehicle driver with four short signal tones (see section 8.2.4.3.2).

When a GO point of sale is visited, the EURO emission class deposited is automatically changed to the EURO emission class for which the proof has been provided. The driver is also issued with a new vehicle declaration at the GO point of sale, and the previous vehicle declaration automatically loses its validity. Therefore the new vehicle declaration must remain in the vehicle.

- b) *Assignment of a EURO emission class to a toll rate group on the basis of the submitted verification documents, which requires the payment of a higher toll tariff:*

In this case, ASFINAG will not wait for the submission deadline, but will instead deactivate the GO-Box immediately, whereby the provisions of section 5.2.2.1.4 shall apply.

- c) *Entry of an incorrect EURO emission class within a toll rate group*

In this case, the EURO emission class determined by the verification of the submitted documents will be entered in the central system.

If the documents submitted as evidence show that the EURO emission class for which evidence was provided would lead to the collection of a lower toll rate in the event of a change in the allocated toll rate group, and if such a change in the allocated toll rate group does occur, two brief acoustic signals (see section 8.2.4.3.1) will alert the driver to the fact that they must go to a GO point of sale to change the EURO emission class stored in the system for their vehicle. If no GO point of sale is visited despite signalling, the GO-Box is subsequently actively disabled, whereby this disabling is announced to the motor vehicle driver with four short signal tones (see section 8.2.4.3.2).

However, if a change in the toll rate group assignment requires the payment of a higher toll rate, the GO-Box is actively blocked without prior signalling by two short signal tones (see Section 8.2.4.3.1) in order to inform about the deposit of the wrong EURO emission class in the GO-Box and to enable the change to the correct (verified) EURO emission class. This blockage is signalled to the driver of the vehicle with four short signal tones (see item 8.2.4.3.2).

In both cases, the next time a GO point of sale is visited, the saved EURO emission class is automatically changed to the EURO emission class for which the evidence was provided. The driver is also issued with a new vehicle declaration at the GO point of sale, and the previous vehicle declaration automatically loses its validity. Therefore the new vehicle declaration must remain in the vehicle.

5.2.2.1.4 No documents are submitted by the submission deadline

If no documents are submitted by the 28-day submission deadline (see section 5.2.3), the GO-BOX will be deactivated. This blockage is signalled to the driver of the vehicle with four short signal tones (see item 8.2.4.3.2). When the driver goes to the next GO point of sale, EURO emission class I is automatically saved on the GO-Box due to the lack of evidence and the box is re-enabled. For the period of time that has elapsed since requesting and entering the EURO emission class for which no evidence was provided by the stipulated submission deadline, a toll evasion offence in accordance with section 10 will have been committed if the road network subject to tolls has been used by the vehicle.

5.2.2.1.5 Documents are submitted, but not by the submission deadline

If the documents are submitted after the submission deadline, the GO-BOX will be deactivated after the deadline elapses, whereby the provisions of section 5.2.2.1.4 shall apply accordingly. Any documents submitted after this point will be considered a new application and the provisions of section 5.2.2.2 shall apply accordingly.

5.2.2.2 Verification in advance

Only for vehicle license plates that have been properly registered for the toll system (active contract) is it possible to submit verification documents to ASFINAG in advance for verification before actually saving the EURO emission class at a GO point of sale (see point 5.2.1). ASFINAG is not obliged to verify documents submitted by owners of vehicles with registration numbers that do not have a valid toll contract. If such documents are nevertheless submitted, ASFINAG is not obliged to keep these documents for verification at a later date.

Once ASFINAG has completed the verification, the EURO emission class for which evidence was provided will be entered in the central system.

In the event of a verification process in advance, the saving of the EURO emission class at a GO point of sale must also be requested. If the EURO emission class requested is the same as the EURO emission class for which evidence was provided in advance, this EURO emission class is entered in the GO-Box. In this case, the vehicle declaration as well as an information document in German and - if available - in the national language of the country of registration of the vehicle license plate, otherwise in English, will be handed over at the GO point of sale, indicating that no further proof is required.

Irrespective of the EURO emission class already saved in the central system (evidenced in advance), a EURO emission class deviating from this can be requested at the GO point of sale (non-compliance). A customer receipt is also issued in this case, which shows the (requested) EURO emission class which is now stored in the GO-Box and which identifies obligations, where applicable (e.g. possible course of deadlines for evidence). In this case, a vehicle declaration of the requested and newly saved EURO emission class as well as the information document in German and - if available - in the national language of the country of registration of the vehicle license plate, otherwise in English, will be handed out at the GO point of sale.

If there is a valid contract and if the documents submitted as evidence (in advance) show that the EURO emission class for which evidence was provided is not the same as the EURO emission class stored in the GO-Box, the following cases are to be differentiated between:

- a) If the documents submitted as evidence show that the EURO emission class for which evidence was provided would lead to the collection of a lower toll rate in the event of a change in the allocated toll rate group, and if such a change in the allocated toll rate group does occur, two brief acoustic signals (see section 8.2.4.3.1) will alert the driver to the fact that they must go to a GO point of sale to change the EURO emission class stored in the system for their vehicle. If no GO point of sale is visited despite signalling, the GO-Box is subsequently actively disabled, whereby this disabling is announced to the motor vehicle driver with four short signal tones (see section 8.2.4.3.2).
- b) If the documents submitted as evidence show that the EURO emission class for which evidence was provided would lead to the collection of a higher toll rate, the GO-Box will, without prior signalling with two short acoustic tones (see section 8.2.4.3.1), be intentionally

deactivated immediately in order to allow the change to be made to the EURO emission class stored in the GO-box. This blockage is signalled to the driver of the vehicle with four short signal tones (see item 8.2.4.3.2). The next time the driver visits a GO point of sale, the EURO emission class is saved.

- c) if the documents submitted as evidence show that the EURO emission class for which evidence was provided does indeed fall in each case in the same toll rate groups as the actual EURO emission class (wrongly) entered in the GO-Box, then section 5.2.2.1.3 c) shall apply accordingly.

If a customer submits documents for verification in advance and does not request the entry of the correct EURO emission class in the GO-Box at the GO point of sale within a reasonable period of time, ASFINAG is entitled to request that the customer re-submits the documents. The holder of the registration certificate or a third party designated by the holder of the registration certificate will be informed of the renewed obligation to provide evidence at the GO point of sale with an information slip in German and - if available - in the national language of the country of registration of the vehicle license plate, otherwise in English.

5.2.3 Documents that are suitable for proving the EURO emission class of a vehicle

The following documents are examples of documents that can be submitted as evidence by the holder of the registration certificate:

1. The vehicle registration certificate (in accordance with Motor Traffic Act 1967, BGBl. No. 267/1967 as amended) or a vehicle document of the same value, as long as this document was issued by the appropriate authority in the state where the vehicle was registered.
2. A COP document (Conformity of Production), as long as this document was issued by the appropriate authority in the state where the vehicle was registered.
3. A CEMT certificate of compliance with the technical and safety standards of the vehicle (hereinafter referred to as 'CEMT certificate' for short), as long as this certificate was issued by the appropriate authority in the state where the vehicle was registered.
4. A Certificate of Conformity (COC) in accordance with appendix IX of Directive 2007/46/EC.
5. A document of confirmation from the vehicle manufacturer in those cases where evidence of the requested EURO emission class cannot be provided using documents 1 to 4 listed above, as long as this letter of confirmation was issued either by the vehicle manufacturer or by a party expressly authorised to do so by the vehicle manufacturer. Evidence that the letter is written by the manufacturer or evidence of the authorisation given to another party to write the letter of confirmation on behalf of the vehicle manufacturer must also be provided.

Moreover, in the case of documents 2 to 5, a copy of the vehicle registration certificate (in accordance with Motor Traffic Act 1967, BGBl. No. 267/1967 as amended) or a document of the same value, as long as this document was issued by the appropriate authority in the state where the vehicle was registered, must also be submitted with the other documents.

The decision regarding the EURO emission class to be entered in the system is made on the basis of

- the documents submitted as evidence,
- the suitability of the documents submitted as evidence, and
- the information and evidence independently obtained by ASFINAG from third parties

hit. No evidence of a particle filter need be provided as this has no bearing on the toll rate.

5.3 GO points of sale

Registration for the toll system is possible via a GO point of sale. GO points of sale are marked as such. A targeted search for GO points of sale is possible at www.go.maut.at. Customers may also refer to the ASFINAG SERVICE CENTER (see section 14) for the exact location of the nearest GO point of sale.

Shielding packaging for the GO-Box is provided at GO points of sale.

GO points of sale are marked with the following signs (see complete figure in Appendix 5):



Figure 20

It is explicitly pointed out that Split GO-Boxes (see point 5.7) are only available at selected GO points of sale and therefore Split GO-Boxes are only issued and (for example in case of a defect) exchanged at these GO POINTS OF SALE. A targeted search for GO points of sale at which Split GO-Boxes are available is also possible at www.go.maut.at.

5.4 Processing fee

When users register with the toll system, a non-refundable processing fee for system access (toll system registration) of €5.00 (incl. 20% VAT) is charged for every GO-Box issued.

5.5 Payment Procedure

5.5.1 General information

The toll can either be paid by settling an account after the toll has been accrued (the post-pay procedure) or by deducting the toll from a previously purchased toll credit (prepaid procedure). The desired payment method must be specified when registering for the toll system and can subsequently be changed (as well as the method and means of payment) at the GO points of sale by presenting the GO-Box and a valid means of payment.

Information regarding the methods and means of payment that are accepted for the post-pay and prepaid procedures can be found in Appendix 2. This information is also available online at www.asfinag.at, at the ASFINAG SERVICE CENTER and at GO points of sale.

A reprint of the collective invoices issued by ASFINAG for the current year as well as the immediately preceding calendar year shall be available in paper form upon request at the ASFINAG SERVICE CENTER for a fee of EUR 5.00 (including 20% VAT) per collective invoice.

5.5.2 About the postpaid procedure

For the post-pay procedure, the toll section rates levied for driving a vehicle that is liable for the toll on the road network subject to tolls are added up and combined to produce a daily charge. This charge is then collected using the appropriate method or means of payment.

If the postpaid procedure is selected, toll transactions will also be settled via the newly issued card in the event of renewal/extension or replacement of the respective fuel card or credit card used due to theft, loss or expiry of validity. ASFINAG is informed of the exchange or renewal/extension of the validity of the card by the card issuer.

If a card is cancelled by a card issuer, the toll cannot be paid (see section 8.2.4.3.2). If, in this case, the driver does not avail of the option of retroactively paying the toll (see section 7.1), they commit a toll evasion offence (see section 10).

5.5.3 About the prepaid procedure

The toll credit in the prepaid procedure must be topped up immediately with an amount of at least EUR 75.00 (incl. 20% VAT) when the GO-Box is handed over to the customer. This also applies for each additional top up process. The toll credit top-up is limited to a maximum €500.00 (including 20% VAT) per GO-Box.

Every time the road network subject to tolls is used, the appropriate toll rate for the toll section that has been used is deducted from the toll credit balance. If the remaining toll credit is insufficient, no debit or partial debit will be made when passing through a toll collection point with a higher toll rate (than the existing toll credit). The driver is notified by an acoustic signal, which sounds as the vehicle passes the toll collection point, that no toll has been collected (see section 8.2.4.3.2). If, in this case, the driver does not avail of the option of retroactively paying the toll (see section 7.1), they commit a toll evasion offence (see section 10).

5.6 Data storage

5.6.1 General information

When a user registers with the toll system (system registration), the following data is stored:

- Country (state) where the vehicle that is liable for the toll is registered
- Registration number of the vehicle that is liable for the toll and the validity of a temporary registration number (optional), details of the motor trader
- Vehicle type (truck and bus, whereby special purpose vehicles are subsumed under the vehicle type 'truck' and motorhomes under the vehicle type 'bus').
- Base category (2, 3 or 4)
- Entered EURO emission class
- Method and means of payment (including expiry dates)
- GO-Box identification number (GO-Box number)
- Personal Account Number (PAN for short)
- First name and surname, or company name of the holder of the registration certificate (optional for the prepaid procedure)
- Address of the holder of the registration certificate (optional for the prepaid procedure)
- Petrol, debit or credit card number (depending on the selected means of payment)
- Telephone number (optional)

- Fax number
- E-mail address (optional)
- Type of drive E/H2

ASFINAG Maut Service GmbH is authorised to store the above-mentioned data and any other data voluntarily provided.

5.6.2 Obligation to inform ASFINAG immediately of changes in the data to be stored in accordance with section 5.6.1

The driver and the holder of the registration certificate are obliged to inform ASFINAG Maut Service GmbH immediately of any changes to the stored data as soon as such a change occurs. Failure to do so means that the driver and the holder of the registration certificate bear sole responsibility for all negative consequences resulting from a failure to provide this information. In particular, the driver is obliged to request the entry of any change in the vehicle registration number and EURO emission class in the GO-Box. Failure to do so may result in the driver committing a toll evasion offence in accordance with section 10.

In the event of a change in the GO-Box identification number, the vehicle license plate or the EURO emission class, a new vehicle declaration will be issued to the driver at the GO point of sale, and the previous vehicle declaration will automatically lose its validity. In this case, evidence must once again be provided in accordance with Section 5.2 or, in the case of a vehicle with a motor trader registration number, in accordance with section 5.6.6.4.

Changes that are not properly made may lead to incorrect toll payment, which constitutes a toll evasion offence (see section 10).

Changes to vehicle data (e.g. the vehicle license plate) must in any case be made at a GO point of sale and the GO-Box and the registration certificate must be presented.

In order to change the pay procedure (i.e. from post-pay to prepaid, or from prepaid to post-pay), the GO-Box and a valid means of payment must be presented at a GO point of sale. In both cases, the new, amended data will be stored in the GO-Box.

The vehicle registration number and the PAN are all that are required to change data relating to the holder of the registration certificate. This data can be changed by calling the ASFINAG SERVICE CENTER.

The data given in an application for exemption in accordance with section 3.3.2 is stored upon submission of such an application.

ASFINAG Maut Service GmbH is authorised to correct and complete of its own accord the data stored in accordance with section 5.6.1. This is most particularly the case in those situations where the driver and the holder of the registration certificate do not meet their obligation to make changes to the data to be stored immediately. The customers' right to demand the correction and completion of data remains unaffected.

The stored data is deleted as soon as and as long as it is no longer required to collect the toll, charge costs, allow for processing, deal with complaints, or fulfil any other legal obligations.

5.6.3 SALE of a vehicle

Within the meaning of Tolling Regulations Part B, any change of the holder of a registration certificate of a vehicle that is liable for the toll constitutes a 'SALE'.

5.6.3.1 SALE of a vehicle without a registration number and without a GO-Box

In the event that a registration certificate holder sells their motor vehicle for which a GO-Box has been issued, the owner shall be obliged:

- either to deregister from the system and return the GO-Box in accordance with section 5.7.4, or
- before further use of the GO-Box in another motor vehicle subject to toll, to arrange for the stored data to be changed in accordance with section 5.6.1.

Failure to do so means that the holder of the registration certificate shall be solely responsible for the settlement and payment of future toll transactions.

Before using the road network subject to tolls for the first time, the BUYER of the vehicle is obliged to re-register with the toll system by providing all the data outlined in section 5.6.1.

5.6.3.2 SALE of a vehicle with a registration number and without a GO-Box

In the event that a registration certificate holder sells their motor vehicle for which a GO-Box has been issued, the owner shall be obliged:

- either to deregister from the system and return the GO-Box in accordance with section 5.7.4, or
- to earmark the GO-Box for a termination of the contract by calling the ASFINAG SERVICE CENTER. Before using the GO-Box for the first time in another motor vehicle liable for tolls, this reservation must be cancelled via the ASFINAG SERVICE CENTER and a change of the stored data must be arranged at a GO point of sale in accordance with section 5.6.1.

Failure to do so means that the holder of the registration certificate shall be solely responsible for the settlement and payment of future toll transactions.

Before using the road network subject to tolls for the first time, the BUYER of the vehicle is obliged to re-register with the toll system by providing all the data outlined in section 5.6.1. Before this new GO-Box is issued, the BUYER must provide the new data in accordance with section 5.6.1 to be stored and pay a provisional administrative fee in accordance with section 5.7.2. This administrative fee will be refunded by ASFINAG Maut Service GmbH upon presentation of the relevant CONTRACT OF SALE.

5.6.3.3 SALE of a vehicle without a registration number and with a GO-Box

Holders of registration certificates who SELL vehicles without a registration number but with a GO-Box are obliged to request the amendment of the stored data in accordance with section 5.6.1. Failure to do so will mean that the holder of the registration certificate shall be solely responsible for the settlement and payment of future toll transactions.

The BUYER must inform ASFINAG Maut Service GmbH immediately in writing that they have taken possession of the GO-Box by providing the GO-Box identification number and the vehicle's

registration number, whereby a copy of the vehicle registration certificate must be appended to this letter.

If the BUYER fails to inform ASFINAG Maut Service GmbH of this change in ownership, they shall be solely responsible for not receiving a collective invoice with the relevant company data and that they will not be able to call up an itemised toll information sheet for the purchased vehicle using the self care access data (i.e. the user name and password provided by ASFINAG Maut Service GmbH).

Any remaining toll credit allocated to a prepaid GO-Box as well as any outstanding claim amounts pursuant to item 7.3, subsequent to settlement, shall automatically pass to the BUYER in the event of the SALE of the motor vehicle and transfer of the GO-Box with the motor vehicle. This is why it is the sole responsibility of the registration certificate holder and the BUYER to reach agreement on such matters.

In case of termination of the contract, any remaining credit balance will be refunded to the means of payment with which this remaining credit balance was topped up.

5.6.3.4 SALE of a vehicle with registration number and GO-Box

Holders of registration certificates who SELL vehicles with a registration number and with a GO-Box are obliged to request the immediate amendment of the stored data in accordance with section 5.6.1. Failure to do so will mean that the holder of the registration certificate shall be solely responsible for the settlement and payment of future toll transactions.

The BUYER must inform ASFINAG Maut Service GmbH immediately in writing that they have taken possession of the GO-Box by providing the GO-Box identification number and the vehicle's registration number, whereby a copy of the vehicle registration certificate must be appended to this letter.

If the BUYER fails to inform ASFINAG Maut Service GmbH of this change in ownership, they shall be solely responsible for not receiving a collective invoice with the relevant company data and that they will not be able to call up an itemised toll information sheet for the purchased vehicle using the SelfCare access data (i.e. the user name and password provided by ASFINAG Maut Service GmbH).

Any remaining toll credit allocated to a prepaid GO-Box as well as any outstanding claim amounts pursuant to item 7.3, subsequent to settlement, shall automatically pass to the BUYER in the event of the SALE of the motor vehicle and transfer of the GO-Box with the motor vehicle. This is why it is the sole responsibility of the registration certificate holder and the BUYER to reach agreement on such matters.

In case of termination of the contract, any remaining credit balance will be refunded to the means of payment with which this remaining credit balance was topped up.

5.6.4 Vehicle RENTAL

Within the meaning of Tolling Regulations Part B, any temporary granting of the right of use of a vehicle that is liable for the toll that does not involve a change of the holder of the registration certificate of the vehicle that is liable for the toll constitutes 'RENTAL'.

5.6.4.1 RENTAL of a vehicle without a GO-Box

In the event that there is no valid registration to the system for the rental vehicle, the LESSEE shall make a registration to the system according to point 5.

In cases where the rented vehicle has already been registered with the system, but the RENTER has not been given the GO-Box, the RENTER is obliged to register with the system in accordance with section 5. Once they have done so, the GO-Box that was previously registered for this vehicle's registration number will be deactivated. Before the GO-Box is issued, the RENTER must provide the new data to be stored in accordance with section 5.6.1 and pay a provisional administrative fee in accordance with section 5.7.2. This administrative fee will be refunded by ASFINAG Maut Service GmbH upon presentation of the relevant rental agreement.

At the end of the period of rental, the RENTER is obliged to

- either deregister from the system and return the GO-Box in accordance with section 5.7.4, or
- to earmark the GO-Box for a termination of the contract by calling the ASFINAG SERVICE CENTER. Before using the GO-Box for the first time in another motor vehicle liable for tolls, this reservation must be cancelled via the ASFINAG SERVICE CENTER and a change of the stored data must be arranged at a GO point of sale in accordance with section 5.6.1.

Failure to do so means that the RENTER shall be solely responsible for the settlement and payment of future toll transactions.

5.6.4.2 RENTAL of a vehicle with GO-Box

Before using the road network subject to tolls for the first time, the RENTER is obliged to call the ASFINAG SERVICE CENTER, on the INTERNET at www.go-maut.at, or at any GO point of sale and provide the data required in section 5.6.1, especially a valid means of payment and the new billing data (in particular the name of the company and the invoice address).

At the end of the rental relationship, the RENTER is also obliged to have the billing data and the means of payment disclosed deleted from the system via the ASFINAG SERVICE CENTER, ONLINE or at www.go-maut.at and at any GO point of sale, otherwise the RENTER bears sole responsibility for the billing and payment of future toll transactions.

The provision of itemised toll information sheets in accordance with section 6 for the period of rental must be requested in advance by calling the ASFINAG SERVICE CENTER and providing evidence of the start and end of the rental period, whereby the RENTER must provide both the registration number of the rented vehicle, their invoice address, and any reference number for the collective invoice.

Any remaining toll credit allocated to a prepaid GO-Box as well as any outstanding claim amounts pursuant to section 7.3, subsequent to settlement, shall automatically pass to the new LESSEE or LESSOR in the event that the vehicle is RENTED out and the GO-Box is passed on with the vehicle. This is why it is the sole responsibility of the RENTER, the new RENTER, and the RENTING COMPANY to reach agreement on such matters.

In case of termination of the contract, any remaining credit balance will be refunded to the means of payment with which this remaining credit balance was topped up.

5.6.5 Interchangeable license plates

In accordance BStMG, the following rule applies to vehicles to which a single license plate number has been allocated (transferable license plates, Wechselkennzeichen):

If these vehicles cannot be allocated to the same toll rate groups, all of the vehicles to which the transferable license plate was allocated are liable for the toll rate of the toll rate groups for which the highest toll rate has been specified.

In the case of an interchangeable license plate, the EURO emission class for which the higher toll rate is set must therefore be saved at the GO point of sale (see point 5.2), unless they are each assigned to the same toll rate groups. This EURO emission class will be entered for the transferable license plate in general and applies to all vehicles using that transferable license plate. Moreover, all evidence relating to all vehicles for which the transferable license plate is used must be submitted to ASFINAG for verification (see section 5.2).

5.6.6 Test drivers and motor trader trips

General remarks

Companies that carry out test drives and/or complete trips in the course of their business as motor traders and who have been issued with one or more test drive registration numbers and/or motor trader registration numbers (transfer license plates) or equivalent foreign registration numbers by an authority (hereinafter jointly referred to as 'motor traders') may avail of the following alternative special provisions:

In amendment of section 5.2, the motor trader may specify to ASFINAG one or more test drive registration numbers or motor trader registration numbers that the company has selected for registration with the toll system (see section 5.6.6.2). Test drive registration numbers and/or motor trader registration numbers shall hereinafter jointly be referred to as 'motor trader registration numbers'.

On the basis of the written registration, ASFINAG shall enter the registered motor trader registration numbers and the EURO emission classes for these registration numbers for which evidence has been provided as motor trader registration numbers in the central system.

A separate declaration of the EURO emission class at a GO point of sale for the transfer sign is only required if no EURO emission class has yet been declared and verified for the transfer sign (see point 5.6.6.3). In this case, the registration form and the vehicle registration certificate must be submitted within 28 days of the declaration. Until such time as the registration is successfully completed, the provisions in section 5.2 shall apply.

For test drives and motor trader trips, the general purpose of verifying the vehicle declaration before the start of the journey (see section 8.2.4.1 and section 8.2.4.2) is to ensure that

- 1) the EURO emission class entered in the correctly installed GO-Box in the vehicle corresponds in each case to the same toll rate groups as the EURO emission class of the relevant vehicle that is being used for the test drive and motor trader trip and that
- 2) the registration number that corresponds to the registration number that has been entered in the GO-Box is properly attached to the vehicle.

If the EURO emission class and/or the registration number do not correspond to the data entered in the GO-Box, the driver must ensure that the data is corrected (see section 5.6.2).

5.6.6.2 Registration and de-registration

The application form provided by ASFINAG must be used to register registration numbers as motor trader registration numbers.

The application form, which is available in a variety of languages,

- can be downloaded from
 - via the SelfCare Portal (www.go-maut.at) or
 - www.asfinag.at;
- can be requested from the ASFINAG SERVICE CENTER.

The application form must be filled out, signed, and submitted to ASFINAG together with a copy of the vehicle registration certificate. The motor trader may submit the application form in one of a number of different ways outlined in section 5.2.2.1. It is not possible to submit the application directly from a GO point of sale. The motor trader must be available to answer any questions ASFINAG might have.

Once ASFINAG has verified the application and if the outcome of the verification is positive, the indicated registration number shall be entered in the central system as a motor trader registration number and the person who submitted the application shall be informed that both the application and the registration have been successful.

If the information provided by the person submitting the application is insufficient or if no information is provided or if there are other reasons that prevent a successful registration, the motor trader cannot be registered and the general provisions outlined in section 5.2 apply.

Applications to de-register motor traders must be made in writing. After de-registration, the general provisions outlined in section 5.2 apply.

5.6.6.3 Declaration of the relevant EURO emission class

As far as the obligation to make a declaration is concerned, ASFINAG differentiates between the following cases:

- a) *The EURO emission class relevant for the respective transfer license plates has already been stored in the central system before registration as a transferor.*

If a EURO emission class has already been correctly declared for the registered motor trader registration number in accordance with section 5.2 before the motor trader was registered, this EURO emission class shall be used for that motor trader registration number. If a different EURO emission class has to be entered for this motor trader registration number, the data must be amended in accordance with c).

- b) *The EURO emission class has not yet been stored for the respective transfer license plates before registering as a transferor.*

Section 5.2.1 applies with the stipulation that in addition to a verification of the registration, evidence must be verified periodically (see section 5.6.6.4). Irrespective of the application, a specific EURO emission class must be requested at the GO point of sale for the transfer license plate. After the saving, a vehicle declaration and an information document will be handed over at the GO point of sale, which refers to the obligation to provide period-related evidence. The information receipt will be given in German and, where available, in the national language of the country in which the vehicle is registered. If an information receipt is not available in that language, an information receipt will be given in English.

- c) *Change to a EURO emissions class already defined for transfer license plates*

In this case, section 5.6.2 applies.

5.6.6.4 Periodical provision of evidence

5.6.6.4.1 *General information*

As part of the registration process, a specific EURO emission class is allocated to the respective motor trader registration number on the basis of the vehicle registration certificate. Evidence of the legitimacy of the entered EURO emission class (i.e. the entry of a EURO emission class to each toll rate group that corresponds to that of the respective vehicle that is used for the test drive and motor trader trip) must subsequently be provided periodically. Periods are defined as follows: the period of time between the 1st and the 15th of every calendar month or the period of time between the 16th and the last day of a calendar month.

The respective test drive and motor trader trip for which evidence must be provided is defined as the trip during which a specific vehicle is transferred to its respective place of destination.

For the first period of a calendar month (i.e. from the 1st to the 15th of the month), completed test drives and motor trader trips must be listed and evidence of these trips must be provided. Both the list and the evidence must be submitted to ASFINAG by the last day of the respective calendar month (hereinafter referred to as the 'submission deadline'). For the second period of a calendar month (i.e. from the 16th to the last day of the month), completed test drives and motor trader trips must be listed and evidence of these trips must be provided. Both the list and the evidence must be submitted to ASFINAG by the 15th day of the following calendar month (hereinafter referred to as the 'submission deadline').

If the requested EURO emission class is allocated to the in each case highest toll rate group, it is not necessary to list the trips and provide evidence of them.

If vehicles with different EURO emission classes, which were allocated to different toll rate groups, were used for consecutive test drives and motor trader trips, then, before the journey is started:

- either the GO-Boxes (that were previously carried in the vehicle) and the registration number must be changed or
- data must be changed (see section 5.6.2).

In any case, the driver must check the vehicle declaration before the start of every test drive and motor trader trip (see section 8.2.4.1 and section 8.2.4.2) to ensure that

- a EURO emission class has been stored in the correctly installed GO-Box in the vehicle that corresponds to the same toll rate groups as the EURO emission class of the relevant vehicle that is being used for the test drive and motor trader trip and that
- the registration number that corresponds to the registration number entered in the GO-Box has been properly attached to the vehicle.

If several registration numbers and GO-Boxes are carried in the vehicle for subsequent test drives and motor trader trips, the driver must ensure that those GO-Boxes that are carried in the vehicle without actually being used are deactivated using the correct cover (see section 3.1.2 and section 8.2.4.1). If the GO-Boxes that are carried in the vehicle without actually being used are not deactivated in this way, toll transactions will be triggered or tolls collected automatically. If this happens, the collected tolls will not be refunded. It should be noted that in this context, it is the responsibility of the driver to take appropriate action in accordance with section 8.2.4.1 and section 8.2.4.2.

5.6.6.4.2 Evidence

All evidence required for the periodical provision of evidence and the lists must be submitted to ASFINAG by the motor trader by uploading the relevant documents via the SelfCare portal.

5.6.6.4.3 Verification of evidence

ASFINAG shall verify the legitimacy of the EURO emission class entered for every test drive and motor trader trip (see section 5.6.6.4.1).

As far as the verification of evidence is concerned, ASFINAG differentiates between the following cases:

- a) *Documents for the right EURO emission class are submitted as evidence before the submission deadline*
In this case, the periodical evidence is considered to have been correctly provided.
- *Timely registration of verification documents for an incorrect EURO emission class*
In this case, a toll evasion offence in accordance with section 10 may have been committed for the relevant test drive and motor trader trip.
- c) *Documents are not submitted as evidence before the submission deadline*
In this case, a toll evasion offence in accordance with section 10 may have been committed for the relevant test drive and motor trader trip.
- d) *No documents were submitted as evidence.*
In this case, a toll evasion offence in accordance with section 10 may have been committed for the relevant test drive and motor trader trip.

5.7 Provisions relating to the GO-Box

5.7.1 General information

Two types of GO-Boxes are distinguished, namely the GO-Box and the Split-GO-Box (both also referred to as the GO-Box), whereby GO-Boxes (and not Split-GO-Boxes) are to be used in all vehicles subject to tolls without a metallised windscreen or with a metallised windscreen and a corresponding DSRC window. If the vehicle that is liable for the toll has metallised windscreens but no corresponding DSRC window, the customer must without exception use a Split GO-Box. This will be provided at selected GO points of sale (see point 5.3).

ASFINAG Maut Service GmbH issues the customer with the GO-Box or the Split GO-Box for use exclusively with the registration number of the vehicle that is liable for the toll and has been registered with the toll system. GO-Boxes are issued free of charge, for a limited period that lasts until the toll system is completely abolished, and for the sole purpose of using the GO-Box to pay the distance-related toll. This means that the customer and ASFINAG Maut Service GmbH conclude a contract of loan for use within the meaning of sections 971 onward of the General Civil Code (ABGB). At the end of the contractual relationship, the customer must therefore return the GO-Box or Split GO-Box to ASFINAG Maut Service GmbH (see section 5.7.4).

The customer or a third party attributable to the customer is responsible for looking after the GO-BOX and handling it with due care for the duration of the loan period. Above all, it is not permissible to change the GO-BOX in any way, for example by opening it, writing on it, changing the colour of its housing, and damaging or rendering illegible either the bar code on the back of the GO-BOX and/or the GO-BOX identification number. In cases where the GO-BOX is damaged either due to

intent or gross negligence —in particular in those cases mentioned above —the customer is obliged to pay the administrative fee outlined in section 5.7.2. The right to assert further claims for damages is reserved.

Claims for damages against ASFINAG and ASFINAG Maut Service GmbH shall be rejected unless caused intentionally or by gross negligence.

5.7.2 GO-Box: period of validity, guarantee, exchange, bearing of costs, and recall

Maximum period of validity of the GO-Box

Depending on the type of contract, the maximum GO-Box validity period in the post-pay procedure is five

years calculated from the time of issue to the customer, in the prepaid procedure two years calculated from the time of the last loading of a toll credit. ASFINAG Maut Service GmbH is entitled to either recall a GO-Box with a view to replacing it or to deactivate a GO-Box before the end of its period of validity even if the GO-Box is being correctly used.

Guarantee

ASFINAG Maut Service GmbH grants the customer a five-year full operability guarantee from the date the GO-Box is issued to the customer. During this period, ASFINAG Maut Service GmbH will rectify any functional faults and ensure that the GO-Box functions properly by exchanging the GO-Box. During the guarantee period, the GO-Box shall be exchanged free of charge as long as the functional faults were not caused by the negligence of the customer or a third party attributable to the customer. In cases of doubt, the customer is obliged to pay the administrative fee (see below). If ASFINAG Maut Service GmbH is subsequently found to be responsible for the fault, this fee will be refunded if and in so far as the customer has submitted a written application (for a refund) to ASFINAG Maut Service GmbH. All claims are satisfied with the exchange of the GO-Box. After the end of the guarantee period, the customer is obliged to return the GO-Box (see section 5.7.4) and to register with the system again (see section 5.1). When re-registering with the system, the customer must pay the necessary processing fee in order to access the system (see section 5.4).

If, however, the customer or a third party attributable to the customer is responsible for the fault, ASFINAG Maut Service GmbH is entitled to charge the customer the following administrative fee (excluding VAT), depending on the amount of time that has passed since the GO-Box was issued to the customer.

Time elapsed since issue	For a GO-Box	For a Split GO-Box
During the first year:	EURO 60.00	EURO 200.00
During the second year:	EURO 48.00	EURO 160.00
During the third year:	€36.00	EURO 120.00
During the fourth year:	EURO 24.00	EURO 80.00
During the fifth year:	EURO 12.00	EURO 40.00

GO-Box recall

The GO-Box will automatically be recalled before the period of validity expires so that it may be replaced. If this recall notification is ignored, the GO-Box will automatically be deactivated (see section 8.2.4.3.2).

Deactivation of the GO-Box

ASFINAG Maut Service GmbH is entitled to deactivate the GO-Box in the event of technical faults or if it discovers irregularities in the collection of tolls. Such irregularities in the collection of tolls, which entitle ASFINAG to deactivate the GO-Box, include cases where tolls that have been accrued by a driver cannot be collected properly. In such cases, the GO-Box sounds a warning signal as an indication that the GO-Box has been deactivated when the vehicle passes a toll collection point (see section 8.2.4.3.2).

Replacement

The replacement of a defective GO-Box is only possible at a GO point of sale upon presentation of the registration certificate; the replacement of a defective Split GO-Box is only possible at selected GO points of sale (see point 5.3).

5.7.2.6 Legal consequences of blocking or using the road network subject to tolls despite expiry of the period of validity

Once the period of validity has expired, or once a GO-Box has been deactivated, no more toll transactions can be made using that GO-Box. If the driver uses the road network subject to tolls despite the expiry of the period of validity or the deactivation of the GO-Box without availing of the option of retroactively paying the toll (see section 7.1), they shall be considered to have committed a toll evasion offence (see section 10).

5.7.3 Theft, loss, and deactivation of the GO-Box

The customer bears sole responsibility for the safekeeping of the GO-Box. In the event of the theft or loss of the GO-Box (hereinafter referred to as 'LOSS' for short), the customer must immediately inform the ASFINAG SERVICE CENTER, giving the relevant GO-Box number and PAN. The GO-Box will be deactivated once its LOSS has been reported. For the LOSS of the GO-Box, an administrative fee defined in section 5.7.2 must be paid before the new GO-Box (also known as a 'replacement GO-Box') is issued and at the latest within one month of reporting the LOSS. No other costs are accrued for the acquisition of a new GO-Box. The customer's obligations in the event of the theft or loss of petrol cards, credit cards, and debit cards depend on the provisions of the respective card issuer (however, see also section 5.5.2).

A LOST GO-Box that is retrieved at a later date can only be reactivated by the ASFINAG SERVICE CENTER upon presentation of the relevant GO-Box number and PAN before a new GO-Box has been issued.

If a LOST GO-Box is retrieved after a replacement GO-Box has been issued, the retrieved (old) GO-Box must be returned in accordance with section 5.7.4. Any remaining toll credit assigned to the old GO-Box was already assigned to the replacement GO-Box before it was issued.

5.7.4 Deregistration, returning the GO-Box, and the lapse of toll credit

The customer deregisters from the toll system by returning the GO-Box. If the GO-Box cannot be returned as a result of theft or loss, the customer must deregister by writing to ASFINAG Maut Service GmbH (see section 5.7.3).

The GO-Box must be returned directly to a GO point of sale or by sending it to ASFINAG Maut Service GmbH (see information under point 14), stating the name, address and bank details. In the event that a GO-Box contract cannot be terminated directly at the GO point of sale in the prepaid procedure, the corresponding GO-Box must also be sent to ASFINAG Maut Service GmbH. The provision of this data is only necessary for the prepaid procedure. Bank account details must only be provided if both a refund receipt and a credit receipt are printed. This will be done in case of a refund of a still existing toll credit if the toll credit has been topped up in cash or with a means of payment that is no longer accepted. Before sending the GO-Box, the customer must ensure that it is deactivated to avoid the triggering of toll transactions or the collection of tolls during transportation. To deactivate the GO-Box, the customer must call the ASFINAG SERVICE CENTER and provide the PAN and the registration number. If the customer does not arrange for deactivation of the GO-Box, any toll transactions triggered or tolls collected during transportation will not be refunded.

If there is still some unused toll credit when the GO-Box is returned (only applies to the prepaid procedure), this sum will be refunded, whereby any unpaid tolls will be invoiced separately in accordance with section 7.3, retroactive billing.

If the unused toll credit is less than the last top up amount, the refund will be made in the form of the means of payment used for the last top up, i.e. either in cash (whereby a payment with Maestro is equivalent to a cash payment) or as a credit to a fuel or credit card. If the unused toll credit is greater than the last amount with which the GO-Box was charged, the last amount with which the GO-Box was charged will be refunded using the means of payment that was last used to charge the GO-Box. The difference between the toll credit and the last amount with which the GO-Box was charged, on the other hand, will be refunded using the means of payment that was used to charge the GO-Box on the last but one occasion. This refund procedure, which is necessary as a result of the current terms and conditions of use for credit cards and petrol card, will be repeated in this manner until such time as the entire toll credit has been refunded.

If a GO-Box is sent to ASFINAG Maut Service GmbH by post in the prepaid procedure, any unused toll credit will only be transferred if the name, address and bank details with the name of the account holder, IBAN and BIC (if the toll credit was generated by payment in cash, with Maestro or with a no longer accepted means of payment) have been disclosed.

Refunds are only credited to the customer's bank account when the unused toll credit exceeds €5.00.

Toll credit (for the prepaid procedure) is only valid for two years from the date of the last charging procedure (top-up). After this period, it is no longer possible to collect tolls. Two months before the end of this two-year period, the GO-Box sounds a warning signal when the vehicle passes a toll collection point (see section 8.2.4.3.1). Toll credit lapses five years after the last charging procedure (in other words, three years after the end of the period of validity) unless more toll credit is charged within this time or the GO-Box is returned. If the GO-Box is topped up again within this

period, the total credit allocated to the GO-Box (old credit plus newly topped-up toll credit) becomes valid.

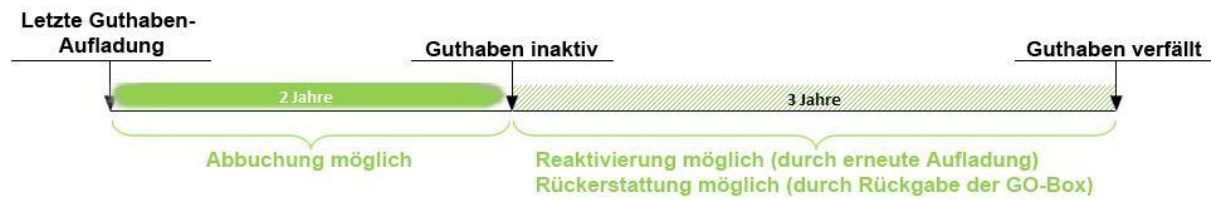

5.7.5 Transportation of GO-Boxes without the obligation to pay the toll obligation

The customer can also obtain shielding packaging for GO-Boxes at GO points of sale (see point 5.3). For those cases where a GO-Box is carried in a vehicle that is not liable to pay the distance-related toll (e.g. when a GO-Box is being transported in a passenger car), the GO-Box in question must be deactivated by ensuring that the cover is properly closed around the GO-Box. To this end, the cover must be wrapped at least three times around the GO-Box and subsequently closed securely using staples or adhesive tape.

If the GO-Box is not disabled, the system will cause a toll transaction or toll debit. If this happens, the collected tolls will not be refunded.

6 ITEMISED TOLL INFORMATION SHEETS AND COLLECTIVE INVOICE STATEMENTS

6.1 Itemised toll information sheets

Itemised toll information sheets that list all automatic toll transactions and retroactively billed toll sections in the post-pay procedure can be obtained (backdated one year) either in printed form from the ASFINAG SERVICE CENTER (on request only) for a fee of €5.00 (including 20% VAT) per itemised toll information sheet and vehicle, or free of charge on the Internet at www.go-maut.at (SelfCare Portal). An itemised toll information sheet, as described above, can also be viewed using the ASFINAG app "Unterwegs", although this is limited to the period of the current calendar and the month immediately preceding it.

Itemised toll information sheets listing automatic toll transactions and retroactively billed toll sections for periods outside this one-year limit will only be supplied by the ASFINAG SERVICE CENTER upon payment of a fee that reimburses ASFINAG for the actual internal costs generated by the specific request.

An itemised toll information sheet is not an invoice; it is for information purposes only. No responsibility or liability will therefore be assumed for the timeliness, correctness, and completeness of the information contained in the itemised toll information sheets.

6.2 Collective invoice statements

If payment is made by credit card, ASFINAG is not aware of the amounts actually paid and cannot, therefore, issue a confirmation of the payment balance. Instead, it can only provide a collective invoice statement that lists the toll charges transmitted to the credit card institute for invoicing purposes. All requests should be made to the ASFINAG SERVICE CENTER.

A collective invoice statement for the six-calendar months preceding the request will be issued for a fee of €5.00 (including 20% VAT) per customer number.

Collective invoice statements for periods outside this six-month limit will only be supplied by the ASFINAG SERVICE CENTER upon payment of a fee that reimburses ASFINAG for the actual internal costs generated by the specific request.

7 SUBSEQUENT PAYMENT OF THE TOLL

7.1 Retroactive payment at GO points of sale/toll enforcement officers

Tolls that have either not been paid or only paid in part for the following reasons can be paid retroactively for vehicles that have been properly registered with the toll system and are equipped with an authorised on-board unit: technical failure of the authorised on-board unit or the toll system, an insufficient prepaid toll credit balance, use of a cancelled means of payment, use of a GO-Box after the period of validity has ended in accordance with section 5.7.2, or the use of an incorrect (too low) category or a toll rate group that is too low. However, retroactive payment is only possible if all of the following conditions are fulfilled. Retroactive payment may only be made for the vehicle registration number for which the toll was not paid or was only paid in part.

- A subsequent payment for an improper toll transaction (no or only partial payment of the toll) can be made at a GO point of sale or to a TOLL ENFORCEMENT OFFICER (see point 9) in the course of the entry (stop), if the subsequent payment of the improper toll transaction is made within the POST PAYMENT AREA.
- The RETROACTIVE PAYMENT ZONE of a TOLL ENFORCEMENT OFFICER is 100 km (in both directions) on the road network subject to tolls, starting at the point where the driver was checked (i.e. the place they were apprehended).
- The RETROACTIVE PAYMENT ZONE of a GO point of sale is 100 km (in both directions) on the road network subject to tolls, starting at the location of the GO point of sale (point of sale on the road network subject to tolls, e.g. at a motorway service area) or starting from the junction closest to the p (point of sale on a lower-ranking road, not on the road network subject to tolls).
- Retroactive payment is only permitted within five hours of the vehicle passing the first toll collection point at which the toll transaction was not correctly made (i.e. the toll was not paid at all or was only paid in part). The reference time of the toll system is used as a reference in this regard.
- Users of GO-Boxes must present them to the GO point of sale to make the subsequent payment.
- The driver of the vehicle that is liable for the toll must inform personnel at the GO point of sale or, if the driver is apprehended (stopped), the toll enforcement officer of the point where the toll was not paid or was only paid in part and, when requested to do so, provide information on how they intend to use the road network subject to tolls in the immediate future.

The toll rate to be paid and, therefore, the amount due is calculated on the basis of the information provided by the driver (regarding the toll station where the toll was not paid or was only paid in part, the actual number of axles on the vehicles at the time the toll was not paid or was only paid in part etc.), the presentation of any evidence (e.g. tachograph), and the presentation of the GO-Box (to avoid double payments, a comparison of the toll transactions stored in the on-board unit may be made). If the amount calculated in this way is lower than €0.10, the amount shall be rounded up to €0.10. Retroactive payment for a EURO emission class that is lower than the actual

(or actually proven) toll rate group presupposes that the driver makes known the EURO emission class that led to the difference in the sum to be paid in the form of a retroactive payment.

If the driver is stopped by toll enforcement officers, the retroactive payment must be made directly to them. In the event that the GO-Box is not permanently affixed and in the event that an official vehicle license plate is not permanently affixed in a visible manner (see section 8.2.4.3), a subsequent payment can only be made at a GO point of sale and not directly to the toll enforcement officers.

In cases where the incorrectly paid toll is retroactively charged automatically in accordance with section 7.3 and in conjunction with section 8.2.4.3.3, retroactive payment is not obligatory.

7.2 Central retroactive payment in the event of use of a too low category or toll rate group

As an alternative to the procedure described in section 7.1, the driver may, if they sets a category or toll rate group that is too low for their vehicle, use the central retroactive payment procedure. This payment requires the customer to provide certain information and must take place within 96 hours of passing the first toll collection point at which the toll was not correctly paid (i.e. only partially paid).

Drivers can use the central retroactive payment procedure as long as the following data is made available by either calling the ASFINAG SERVICE CENTER or by submitting it via INTERNET:

- PAN;
- the GO-Box identification number of the GO-Box that was used at the time the toll was not correctly paid;
- the country and registration number entered in the GO-Box;
- the correct category and the correct EURO emission class;
- the date and time when the toll was not correctly paid;
- provision of a valid means of payment in accordance with section 3.1.2 of Appendix 2 that can be used for central retroactive payment;
- the name and invoice address (for anonymous prepaid customers) in cases where an anonymous prepaid customer would like to receive an invoice.

Central retroactive payment can also be made using the ASFINAG app “Unterwegs” (only when using the post-pay procedure). In addition to selecting the vehicle concerned (registration number and registration country) with the respective GO-Box identification number, it is also necessary to enter the official category or the official EURO emission class as well as the time period (date and time) for which the central retroactive payment should be made. The payment can only be made using the post-pay payment method stored in the GO-Box. If central retroactive payment is not possible via the ASFINAG app “Unterwegs” (if, for example, the GO-Box has been exchanged in the meantime or changed to the prepaid procedure), then it is mandatory to use a different option for the toll payment.

Central retroactive payment is by all means only an option in those cases where at least one toll transaction was only partly paid during the period of time in question.

For technical reasons, central retroactive payment can only be made once for the given toll section and period; subsequent corrections after payment are not, therefore, possible.

The toll rate to be paid and, therefore, the amount due is calculated on the basis of the information provided by the customer to the ASFINAG SERVICE CENTER, on the INTERNET or using the

ASFINAG app “Unterwegs” (the date and time when the toll was not correctly paid etc.). If the amount calculated in this way is lower than €0.10, the amount shall be rounded up to €0.10. If the driver is stopped by toll enforcement officers, the retroactive payment must be made directly to them.

7.3 Retroactive settlement

ASFINAG has the right to bill customers automatically for tolls that have not been paid in situations complying with section 8.2.4.3.3 and in cases where ASFINAG has chosen not to erect a toll collection point on a specific toll section (see the fourth paragraph of section 1).

Retroactive billing only occurs in cases where a customer uses a road section subject to toll charging but where a toll transaction was not correctly made. The retroactively billed toll for the relevant road section subject to toll charging corresponds exactly to the toll section rates listed in Appendix 4 of the Tolling Regulations at the time the toll transaction was not made. This applies equally to retroactive billing for both the prepaid and post-pay procedures.

Prepaid procedure:

Each motor vehicle driver will be requested to pay the subsequently charged amounts on the spot at the next customer contact at a GO point of sale following the improper payment of the toll. The customer will be given a special receipt for the retroactively billed amount, which contains a detailed listing of the toll sections for which a toll was retroactively billed. Toll credit can only be recharged, data changed, and contracts terminated once this retroactively billed toll has been paid in full. It is not permissible to offset the retroactively billed toll against any existing toll credit.

Post-pay procedure:

In the post-pay procedure, retroactive billing is settled without any extra activity on the part of the customer; the retroactively billed toll is simply added to the periodical collective invoices or petrol card invoices that are sent to the customer.

8 OBLIGATIONS OF MOTOR VEHICLE DRIVERS

8.1 Correct installation of the GO-Box

The GO-Box shall only be installed in the authorised vehicle that is liable for the toll and carries the registration number to which the GO-Box has been registered. It has to be permanently installed in the following part (see figure 21):

- The GO-Box must be attached to the inside of the windscreen between the centre of the vehicle and the centre of the steering wheel.
- It must be attached to that part of the windscreen that is cleaned by the windscreen wipers and in such a way that the GO-Box control key faces the interior of the vehicle.
- The GO-Box is at least 10 cm above the windscreen wiper in the rest position and
- must be mounted at least 30 cm below the upper edge of the windscreen.
- The attached GO-Box must not impede vision while driving.
- An area of the windscreen surrounding the GO-Box with a radius of 10 cm must be kept free of all objects and vehicle parts (e.g. sun shades).
- The GO-Box should not be attached to the windscreen behind a strip of tinted glass.
- The driver is also obliged to keep all objects that could impair operation of the control keys away from the GO-Box.

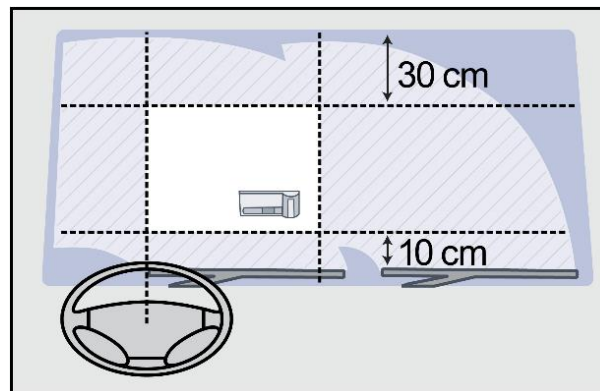

Figure 21: the correct installation of the GO-Box

The GO-Box may not be attached in a different area without prior single-approval in written form by ASFINAG Maut Service GmbH.

The installation of a Split GO-Box is subject to its own rules, which can be found in the respective operating instructions or the Split GO-Box Guide.

8.2 Correct operation of the GO-Box

8.2.1 Example for GO-box

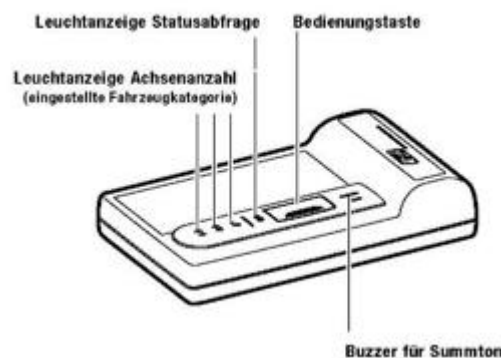

Figure 22

8.2.2 Declaring and setting the vehicle category (not applicable for buses and motor caravans)

When the GO-Box is issued, a base category is set for the vehicle that is liable for the toll on the basis of the vehicle's number of axles (the base category constitutes the lowest category that can be manually set). The driver is obliged to check the category in accordance with section 8.2.4.2 before starting each journey.

If a trailer or a road semi-trailer is attached to the vehicle, the driver is obliged to change the vehicle category to the correct category. For the declaration of the category to be set, the actual number of axles of the tractor unit together with the number of axles of the (semi-)trailer is decisive,

regardless of the maximum permissible total weight of the (semi-)trailer. The user can increase the category by pressing the control key for longer than two seconds (the base category follows category 4 in the sequence). Once the category has been changed, the appropriate LED (category 2-4) will flash, thereby indicating the newly set category.

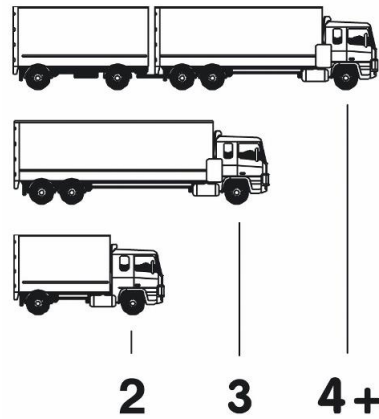

Figure 23

If the vehicle driver mistakenly declares a higher category than the actual category for the vehicle or combination of vehicles that is liable for the toll and consequently pays/is charged the wrong toll rate, ASFINAG can refund the excess toll paid once the reasons for the mistake have been stated and corresponding evidence provided. Applications for refunds must be accompanied by the corresponding evidence and submitted within three months of the date on which the excess toll was paid. Applications should be submitted directly to ASFINAG Maut Service GmbH (see section 14).

8.2.3 Declaring and setting the vehicle category (buses and motor caravans)

When the GO-Box is issued, a base category is set on the basis of the bus or motorhome's number of axles (definition given in section 2(1)(28a) of the Motor Traffic Act 1967). See also the figure in section 8.2.2. It is not necessary to change the base category because trailers attached to buses or motorhomes are not taken into account when counting the number of axles.

8.2.4 Checking that the GO-Box is in working order

8.2.4.1 The driver's duties

In accordance with section 8(2) BStMG, drivers must check that the GO-Box is in technical working order before, during, and at the end of every trip on the road network subject to tolls and report any malfunctions or faults immediately; set the number of axles on the GO-Box; and carry any evidence outlined in section 5.2.3 that allows the allocation of the EURO emission class to a toll rate group to be checked. The driver's general obligations also include the obligation to familiarise themselves with the meaning of the different GO-Box acoustic signals described in section 8.2.4.3 and to act in accordance with sections 8.2.4.2 to 8.2.4.4. Furthermore, they should carry a shield cover in the vehicle that is liable for the toll (see section 3.3.3).

The driver is obliged to check the vehicle declaration they were given at the time the EURO emission class was declared in accordance with section 5.2 and to carry this document in the vehicle.

If the vehicle declaration is lost or damaged, it must be reprinted. This can be done at any GO point of sale or centrally from the SelfCare portal.

In the event of any changes in data that affect in particular the vehicle registration number, the entered EURO emission class, or the GO-Box identification number, the issuing of a new vehicle declaration must be requested at a GO point of sale, whereby the old vehicle declaration becomes invalid. The procedure that must be observed in this case is outlined in section 5.6.2.

8.2.4.2 Before starting the trip

Before driving on the road network subject to tolls, the driver must make sure that the GO-Box is technically functional by pressing the control button once (for less than two seconds) (status check). The status request is only used to check the technical functionality of the GO-Box. The LED that lights up during the status check does not, however, inform the driver of any existing reasons for a deactivation of the GO-Box; the driver is only alerted to the payment or the non-payment of the toll by the various acoustic signals emitted by the GO-Box (for more information on the meaning of the acoustic signals and the actions the driver must take in response to these signals, see section 8.2.4.3).

The obligation to check that the GO-Box is in working order also includes the correct category declaration and setting in accordance with section 8.2.2.

- If both the "Status request" and "Number of axles" indicator lights flash "green" once briefly, this means that the GO-Box is technically functional.
- If the "Status Request" indicator light flashes "red" twice briefly and the "Number of Axles" indicator light flashes "green" twice briefly, this means that the GO-Box is technically functional. These LEDs also indicate that the toll credit balance in accordance with the prepaid procedure has dropped below the fixed limit (€30.00). The driver must ensure at their own discretion and on their own responsibility that the toll credit is recharged in time.
- If the 'Status check' LED briefly flashes 'red' four times, no tolls can be collected. In this case, the driver must go immediately to the nearest GO point of sale or refrain from driving on the road network subject to tolls.
- If the 'Status check' LED and the 'Number of axles' LEDs do not flash (no flash), the GO-Box is not in working order. In this case the driver must immediately go to the nearest GO point of sale and fit their vehicle with a new functional GO-Box before continuing their journey (for replacement see section 5.7.2).

Moreover, before starting the trip, the driver must check the following on the basis of the vehicle declaration:

- that the vehicle registration number attached to the vehicle is the same as the official vehicle registration number printed on the vehicle declaration and
- the GO-Box identification number of the GO-Box in the vehicle is the same as the GO-Box identification number in the vehicle declaration.

If either or both are not the same, the driver must visit the nearest GO point of sale and request a corresponding change of the data in the GO-Box in accordance with section 5.6.2. The difference in the toll accrued for the use of the sections of the road network subject to tolls used to reach the GO point of sale must be paid retroactively in accordance with section 7.

Failure to do so may result in the driver committing a toll evasion offence in accordance with section 10.

8.2.4.3 During the trip

For the duration of the use of the road network subject to tolls, the GO-Box must be properly and permanently attached to the windscreen of the vehicle in accordance with section 8.1.

In order to ensure that the toll can be properly collected, the driver must in accordance with section 102 KFG make sure that the official registration number of the vehicle liable for the toll is completely visible at all times during the trip and is not rendered illegible by dirt, snow, damage, or deformation. Whenever the vehicle passes a toll collection point, the driver will hear the following acoustic signals. The driver should note the difference between acoustic signals that must be observed and those that provide information.

8.2.4.3.1 *The following acoustic signals provide vehicle drivers with information:*

- One brief acoustic signal: Toll payment is confirmed on the basis of the set category and the EURO emission class stored in the GO-Box.
- Two brief acoustic signals: Although payment of the toll is confirmed on the basis of the set category and the EURO emission class stored in the GO-Box, the driver must go to the nearest GO point of sale immediately.

Failure to do so can lead to the automatic deactivation of a GO-Box (see section 8.2.4.3.2).

This information signal is heard in the following cases in particular:

- the toll credit (only applies to the prepaid procedure) has dropped below the limit of €30.00 (the user must ensure that the toll credit is topped up in time),
- the toll credit will lapse within the next two months (only applies to the prepaid procedure),
- - the period of validity of the GO-Box will expire within the next two months,
- - the data stored in the GO-Box must be changed,
- - the customer is requested to exchange the GO-Box or
- - to check the correct mounting of the GO-Box

8.2.4.3.2 *The following acoustic signal must be observed by the vehicle driver:*

- Four short beeps: No toll payment has been made.

This signal is heard in the following cases in particular:

- provisions in Tolling Regulations Part B were not observed by the customer,
- the GO-Box was deactivated as a result of a recall so that the GO-Box can be exchanged,
- technical faults or observed irregularities relating to toll collection,
- the entry of the incorrect EURO emission class, or
- the toll credit in the prepaid procedure is not sufficient to settle the toll amount due.

In this case, the vehicle driver is obliged to pay the toll retroactively and in full in accordance with section 7.1. Failure to comply with this provision constitutes a toll evasion offence in accordance with section 10.

8.2.4.3.3 *No acoustic signal:*

If no acoustic signal sounds, no toll was paid. There is no obligation to pay the toll retroactively in accordance with section 7.1 as long as all of the following conditions are met without exception:

- The GO-Box is properly installed in accordance with section 8.1.
- At the time of passing through a toll collection point, a valid means of payment was saved for the GO-Box in the postpaid procedure or the toll credit assigned to the GO-Box was loaded with a sufficient amount in the prepaid procedure.
- The user checked that the GO-Box was in proper working order in accordance with sections 8.2.4.2 and 8.2.4.4.
- The category of the vehicle that is liable for the toll has been correctly set in the GO-Box in accordance with section 8.2.2
- The registration number of the vehicle that is liable for the toll was correctly registered with the system in accordance with section 5.6.

If any one of these conditions is not met, the user is obliged to pay the toll retroactively in accordance with section 7.1.

To verify the acoustic signals, the correct payment of the toll can be checked at any GO point of sale.

Drivers with a hearing disability are not exempt from these obligations. They are obliged to check that the toll has been properly paid at the aforementioned GO points of sale (see also section 8.2.4.4). Before doing so, the customer may also contact the ASFINAG SERVICE CENTER (see also section 5.3) to inquire whether the toll system is in working order.

8.2.4.4 *After the trip*

After all trips on the road network subject to tolls, the driver must once again check that the GO-Box is in technical working order and, if the GO-Box is not in proper working order (according to the provisions in section 8.2.4.2) must pay any unpaid or partially paid tolls by means of retroactive payment in accordance with section 7.1. Failure to comply with this provision constitutes a toll evasion offence in accordance with section 10.

9 MONITORING ADHERENCE TO THE TOLL OBLIGATION

9.1 Toll enforcement officers and their powers

Compliance with the payment of tolls based on mileage is monitored (in addition to automatic checks) by toll enforcement officers. The toll enforcement officers are organs of public supervision. They are appointed and sworn in in accordance with the provisions of § 17 (2) BStMG.

For the purpose of checking that tolls have been paid correctly, the toll enforcement officers are empowered, among other things, to request drivers to stop by using clearly visible or audible signs, to stop them, to check the affixing of the vignette sticker or the registration of the license plate in the tolling system, to establish the identity of the driver and of the license holder, the motor vehicle, in particular the registration certificate, evidence of assignment to a tariff group (in particular type certificate and vehicle declaration), the GO box or other on-board equipment, the tachograph, the odometer, the recording equipment in accordance with Regulation (EEC) No 3821/85 as last

amended by Regulation (EC) No 432/2004 and - in the case of journeys with test or transfer license plates within the meaning of point 1.2 - to check evidence of the vehicle's tare weight (in particular a copy of the type certificate), and to ask drivers to pay any substitute toll due.



Figure 24

Moreover, in order to monitor the correct payment of tolls and to conduct traffic surveys, toll enforcement officers are empowered to use automatic traffic diversion equipment to divert traffic to toll inspection areas. Toll inspection areas are currently situated at the following locations: A1 Eberstalzell, A1 Haag, A1 Walserberg, A2 Arnoldstein (on the entry side and on the exit side), A2 Arnwiesen, A2 Haimburg, A2 Ilztal, A6 Kittsee (on the exit side), A4 Bruck/Leitha (travelling towards Vienna), A4 near Nickelsdorf (on the exit side), A4 Gols (travelling towards Vienna and travelling towards Nickelsdorf), A4 Zurndorf (travelling towards Vienna), A5 Schrick, A8 Kematen, A8 Suben, A9 Liesingau, A9 Liezen, A9 Schoberpaß, A9 Straß, A9 Trieben, A9 Übelbach, A9 Windischgarsten, A10 Hoher Göll, A10 Kellerberg, A11 near Rosegg, A11 Karawanken Tunnel (on the exit side), A12 – inspection bay Roppener Tunnel Ostportal (km 125,80, travelling towards Bregenz), A12 – inspection bay Zirl Ost, A12 junction Wörgl-Ost (in both directions), A14 Hörbranz (on the entry side and on the exit side), A14 Nüziders, S4 Pöttsching (travelling towards Wr. Neustadt), S3 – inspection point Göllersdorf (travelling towards Stockerau), the Bings "Kettenanlageplatz" (a bay where drivers can attach snow chains to the tyres on their vehicles) on the S16 (travelling towards Innsbruck), S31 Hirm Nord (travelling towards Eisenstadt), S31 Hirm Süd (travelling towards Mattersburg), and S37 near Maria Saal.

Additionally, toll enforcement officers may also monitor the correct payment of tolls and conduct traffic surveys at border crossings and junctions.

If the substitute toll is not paid and if criminal prosecution or enforcement of the penalty appears to be impossible or significantly impeded, toll enforcement officers are authorized in accordance with § 27 BStMG to collect a provisional security or, until the stipulated provisional security is paid, to order the interruption of the journey in accordance with § 28 BStMG and to prevent its continuation using suitable precautions (confiscation of the vehicle keys and documents, attachment of technical barriers to the vehicle to prevent it being moved, parking at a suitable location, etc.).

Provisional security deposits may be provided in cash (euros) or using an authorised means of payment (Appendix 2).

9.2 Toll enforcement officers' identification cards

The identity card of the toll enforcement officers, which confirms their official capacity and which must be carried on duty or shown to those concerned upon request, is printed on both sides, is the size of a credit card and contains the following information in particular: the photograph, name and service number of the toll enforcement officer (see Figure 25).



Figure 25

9.3 Toll enforcement officers' vehicles

The toll enforcement officers' vehicles are public security force enforcement vehicles that comply with the section 20 para. 1 line 4 lit. a of the Motor Vehicle Act 1967. These vehicles are silver-grey operational vehicles that are equipped with flashing blue lights and a siren. Furthermore, the enforcement vehicles are marked with the following words: "ASFINAG", "toll enforcement" and "ASFINAG service and toll enforcement unit" (see Figure 26).



Figure 26

10 TOLL EVASION

10.1 Penalties for toll evasion

It is prohibited to drive a vehicle that is liable for the toll within the meaning of Tolling Regulations Part B on the road network subject to tolls without correctly paying the distance-related toll. In accordance with section 20(2) BStMG, drivers who violate this prohibition are in breach of an administrative rule, which is punishable by the local district administrative authorities by imposing a fine of €300.00 and €3,000.00.

If the driver of a vehicle that is liable for the toll is apprehended on the road network subject to tolls and found not to have a GO-Box or another authorised on-board unit in the vehicle, they must leave the road network subject to tolls immediately at the next possible exit.

Should the holder of the registration certificate not provide evidence of the legitimacy of the requested EURO emission class in due time in accordance with the tolling regulations, the provisional allocation to the declared toll rate group will expire retroactively (*ex tunc*) in line with section 9 subsection 11 BStMG. In that case the vehicle is assigned to the toll rate group with the highest rate retroactively. Pursuant to § 20 para. 3 BStMG, owners of a vehicle who fail to provide proof of the vehicle's allocation to the declared EURO emission class within the specified period and thereby cause the improper payment of the mileage-based toll for the use of toll sections are committing an administrative offence. This administrative offence shall be punished by the district administrative authority with a fine of between EUR 300.00 and EUR 3,000.00.

10.2 Non-imposition of a penalty

A penalty will not be imposed if a substitute toll - as described below - is paid. Any substitute toll duly paid in accordance with § 19 BStMG cannot be reclaimed (§ 20 para. 6 BStMG).

10.3 Substitute toll

10.3.1 Method of payment

10.3.1.1 Apprehension by toll enforcement officers

If the driver of the vehicle is apprehended by toll enforcement officers, the toll must be paid retroactively if the conditions in section 7.1 are met. If the driver refuses to pay the toll retroactively or if the conditions in section 7.1 are not fulfilled, the toll enforcement officer is empowered to verbally request that the driver pay the substitute toll. The substitute toll is to be paid immediately upon request, either in cash (EURO) or with an approved payment method (Appendix 2). The vehicle driver shall be issued with a confirmation of the payment made and a list of the toll sections affected.

10.3.1.2 Retroactive summons procedure

If a violation is detected by toll enforcement officers during the course of their work or if the incorrect payment of the toll was detected through automatic checks without the driver being apprehended in person, the/a holder of the registration certificate may receive a written request to pay the substitute toll. In cross-border procedures, the request for payment of the substitute toll is made in the form of an information letter in accordance with section 30b para. 1 of the BStMG, which is listed as a model in Appendix 8 to the tolling regulations.

In addition to the amount of the substitute toll to be paid, the written request shall contain, among other things, an identification number or an invoice number and the claimant's bank details. The substitute toll must be transferred to the account specified in the request for payment or the information letter in accordance with section 30b para. 1 BStMG, stating the identification number or invoice number specified in the request. The obligation to pay the substitute toll is met when the substitute toll has been credited to the given account within four weeks of issuing the request and as long as the transfer order contains the complete and correct identification number or invoice number, which must be written in such a way that it can be automatically read by a machine. The substitute toll may not be paid in instalments. If instalments are received, they will be credited to the payer's account minus a processing fee of €15.00 (including 20% VAT). This also applies to late payments and payments without stating the correct identification number or invoice number,

as well as payments to an account other than the one disclosed on the copy of the request or the information letter pursuant to Section 30b para. 1 BStMG for payment of the substitute toll. In the event of overpayment by less than €5.00, no money will be credited to the payer's account (otherwise the entire amount will be credited to the payer's account).

10.3.2 Substitute toll rate

The substitute toll rates (including 20% VAT) for the incorrect payment of the distance-related toll are given below:

REASON FOR SUBSTITUTE TOLL	SUBSTITUTE TOLL RATE
<p style="text-align: center;">Not properly or timely provided proof of</p> <ul style="list-style-type: none"> • the requested EURO emission class or • the drive type of a vehicle with a purely electric drive unit or with a hydrogen fuel cell drive 	EUR 240.00
Complete non-payment of the toll	EUR 240.00
<p style="text-align: center;">Partial payment of the toll</p> <p style="text-align: center;">1. <u>Case</u> Use of a wrong category (number of axles)</p> <p style="text-align: center;">2. <u>Case</u> Non-conformity</p> <p>a) the registration number attached to the vehicle is not the same as the registration number given in the vehicle declaration (toll rate-related vehicle registration number violation) or</p> <p>b) the GO-Box identification number of the GO-Box in the vehicle is not the same as the GO-Box identification number in the vehicle declaration</p>	EUR 120.00

In the event of a coincidence of several acts, each of which separately represents a partial payment of the toll (i.e. coincidence of the partial payment of the toll after the first case and partial payment of the toll after the 2nd case), only a request for payment of the substitute toll or an information letter pursuant to section 30b para. 1 BStMG is sent in the offence-relevant period.

10.3.3 Initiation of administrative penal proceedings

If a driver is apprehended and requested to pay a substitute toll or if following a written request, a substitute toll is not paid, is paid in part, or not paid on time, administrative penal proceedings shall be initiated.

11 DATA PROTECTION AND DATA SECURITY

ASFINAG is entitled pursuant to § 16a BStMG to process the personal data required for toll collection, toll collection and the prosecution of toll evasion with the aid of automation.

To verify if the toll has been paid properly and to trace toll evasion, in accordance with section 19a BStMG, ASFINAG is entitled to use technical equipment. The image data and license plate number and control data obtained from it may be processed for the purposes of collecting the toll, requesting payment of a substitute toll or an information letter in accordance with section 30b para. 1 of the BStMG and prosecuting toll evasion.

More detailed explanations of the data protection principles and information on the rights of data subjects are available on the internet at www.asfinag.at.

12 VIOLATION OF THE OBLIGATION TO STOP

Drivers who, contrary to section 18(2) BStMG, do not stop when instructed to do so by a toll enforcement officer are in breach of an administrative rule in accordance with section 21 BStMG and shall be fined up to **€3,000.00**.

13 PLACE OF JURISDICTION AND APPLICABLE LAW

The exclusive place of jurisdiction for all claims against ASFINAG under civil law arising out of these Tolling Regulations and/or the use of the road network subject to tolls shall be the court that has jurisdiction as regards such matters for the first district in Vienna. Only Austrian law applies, excluding the conflict of laws rules of private international law.

14 RESPONSIBILITY AND CUSTOMER SERVICE (ASFINAG SERVICE CENTER)

ASFINAG has entrusted ASFINAG Maut Service GmbH with the operation of the toll system and the collection of the toll on behalf of and for the account of ASFINAG. ASFINAG Maut Service GmbH is the company to contact for all procedural questions relating to the distance-related toll.

ASFINAG Maut Service GmbH

Alpenstraße 99

A-5020 Salzburg, Austria

Tel.: 0800 400 12 400 (free of charge from Austria and Germany)

Tel.: +43 (1) 95 51 266 (not free of charge when calling from all other countries)

Fax: +43 (1) 95 51 277

E-Mail: info@asfinag.at / <http://www.asfinag.at>

15 SPECIAL PROCEDURES IN CONJUNCTION WITH MOTOR VEHICLES POWERED PURELY BY ELECTRIC OR HYDROGEN FUEL CELL

For motor vehicles powered purely by electric or hydrogen fuel cell (hereinafter referred to as: E-/H2 motor vehicles), Part B of the tolling regulations applies in full.

The regulations in Part B on the EURO emission class (such as the declaration or proof) also apply mutatis mutandis to E/H2 motor vehicles.

For E-/H2 motor vehicles, the rates shown in Appendix 4i apply. The use of the rate for E-/H2 vehicles requires that the motor vehicle's sole drive system be proven to ASFINAG to be either electric or hydrogen fuel cell.

In addition to the ways to provide evidence for EURO emission classes, you can also e-mail it to eh2@asfinag.at.

PART C: INTEROPERABILITY

In order to pay the toll in Austria, customers may use other on-board units (OBUs) in accordance with section 7 BStMG as long as these OBUs are authorised in accordance with the provisions below.

In order to use the authorised OBUs listed below, the provisions of Tolling Regulations Part B shall apply unless provisions are made in the sections that follow for special cases and/or deviations.

Should a vehicle be used that has a purely electric drive unit or a hydrogen fuel cell drive unit pursuant to Part C, the specifications concerning the EURO emission classes (most notably evidence thereof) shall, in turn, also apply to these vehicles.

1 THE AUTHORISATION OF ON-BOARD UNITS USED FOR THE SWISS LSVA TOLL SYSTEM

1.1 General information

The Eidgenössische Zollverwaltung, Oberzolldirektion, Bern, (hereinafter also referred to as 'OZD') on the one hand and ASFINAG, represented by ASFINAG Maut Service GmbH (hereinafter also referred to as 'ASFINAG'), on the other provide a service to customers that allows customers of both toll systems to use the Swiss on-board unit to pay tolls in both Switzerland/Liechtenstein and in the Republic of Austria (hereinafter referred to as 'service'). The provision of this service does not affect the toll jurisdiction of either state.

Payment of the obligatory toll charges is still handled by the relevant toll collector (dual contract interoperability).

The following Swiss on-board units are authorised for the payment of tolls in Austria in accordance with section 7 BStMG

- Tripon
- Emotach

The on-board unit can only be used to pay tolls in conjunction with the post-pay procedure (for details on the methods and means of payment that are accepted for this procedure, see Appendix 2 of the Tolling Regulations). Toll payment according to the prepaid procedure is not possible.

The simultaneous use of several on-board units that are authorised in Austria for electronic toll payment can lead to multiple payments of the toll and is, therefore, impermissible. Any toll overpayments due to this will not be refunded.

1.2 Provisions relating to the on-board unit

On-board units may only be obtained from and returned to the OZD in accordance with the conditions governing the Swiss LSVA toll system. They must be installed and kept operable in accordance with the standards of the LSVA toll system (see www.zoll.admin.ch for details). All questions regarding the on-board unit should be directed to the OZD. ASFINAG cannot maintain, repair, or exchange on-board units.

1.3 Registration

1.3.1 Registration procedure

Before the on-board unit is used to pay tolls in Austria for the first time, the vehicle that is liable for the toll must be registered. The relevant registration forms, which are available on the INTERNET at www.go-maut.at or from the ASFINAG SERVICE CENTER, must be used for registration.

The person registering with the system will be informed in writing by ASFINAG whether the registration has been accepted by ASFINAG and the OZD. If the registration is accepted, the holder of the registration certificate will receive a chip card from the OZD within ten days. This card can be used to activate the on-board unit in Austria. The on-board unit indicates whether the unit is ready for use in Austria by displaying the codes '1001' or '1101' in the 'Gerät' (OBU) data field in the 'INFO/Fixe Daten/Vertrag' (Info/Fixed data/Contract) menu.

It is the sole responsibility of the customer to activate the on-board unit and to use the on-board unit properly in Austria.

The relevant registration forms, which are available on the INTERNET at www.go-maut.at or from the ASFINAG SERVICE CENTER, must be used when changing customer data.

In those cases where the Swiss on board unit is used and a correct toll collection in Austria can not be ensured (in particular in cases where vehicles have transferable license plates) ASFINAG will exercise the right of refusal.

1.3.2 Declaration of the EURO emission class and changing data

Because the EURO emission class is not stored in the on-board unit and because the on-board unit is permanently installed and cannot be presented at a GO point of sale, documents that are required as evidence may only be submitted in advance. To this end, the provision of a valid e-mail address or other contact address is absolutely essential.

On the calendar day following conclusion of the document verification process (see section 5.2 of Tolling Regulations Part B), the proven EURO emission class will be entered in all toll gantries. Once this has occurred, this EURO emission class becomes relevant for the tolls to be paid. The claim to the billing of the toll rate for the proven EURO emission class begins the moment the EURO emission class is correctly entered in the relevant toll gantry.

Once the document verification process has been concluded, the valid vehicle declaration will be sent to the customer either per e-mail or by post. The vehicle declaration can also be obtained free of charge from a GO point of sale or in the SelfCare Portal at any time.

In the event of a data change, the documents suitable for proving the EURO emission class in accordance with item 5.2.3 of Part B of the Tolling Regulations shall be submitted to ASFINAG for verification. Existing customers shall provide ASFINAG with the relevant verification documents in accordance with item 5.2 of Part B of the Tolling Regulations.

1.4 Data exchange

By registering with the system, the customer authorises the OZD and ASFINAG to save and exchange data relating to the customer and the vehicle that is liable for the toll and that is required for use of the on-board unit.

In order to ensure that tolls are paid correctly in Austria, ASFINAG and the OZD exchange the following data:

- business partner number
- LSVA master number
- vehicle registration number and country
- Personal Account Number (PAN)
- on-board unit identification number (OBU-ID)

1.5 Obligations of motor vehicle drivers

1.5.1 The correct installation and operation of the on-board unit and the setting of the category in the on-board unit

The correct installation and operation of the on-board unit and the setting of the category are based on the relevant rules of operation for the on-board unit in use. For this reason, the on-board unit must be installed and kept operable in accordance with these standards.

Before beginning the journey, the driver must indicate on the on-board unit whether a trailer is attached to the vehicle. The declaration that a trailer is attached to the vehicle automatically triggers toll collection according to the rates in category 4.

1.5.2 Checking that the on-board unit is in working order

Once they have registered with the system, the vehicle driver must check before the start of every journey whether the on-board unit is working properly and whether toll payment in Austria is possible.

In the event that a toll payment in Austria cannot be made with the on-board unit, the customer shall be obliged to use an Austrian GO-Box in accordance with Part B of the tolling regulations. The Austrian GO-Box can be obtained at any GO point of sale. It is expressly pointed out that the driver of the motor vehicle must in particular ensure that when changing to the Austrian GO-Box they also fulfil their obligations to pay the toll in accordance with point 7 of part B of the tolling regulations. This is a very important point because failure to do so (i.e. failure to pay accrued tolls after switching to a GO-Box) can constitute a toll evasion offence in accordance with section 10 of Tolling Regulations Part B.

1.6 Signals emitted by the on-board unit

When the vehicle passes a toll collection point, the 'short' acoustic signal emitted by the on-board unit indicates that the toll has been paid.

If the toll has not been correctly paid, either a 'long' acoustic signal (e.g. the on-board unit has been deactivated or the transaction has failed) is emitted or no acoustic signal is generated (no transaction made, e.g. because of a technical error). In such cases, the driver must pay the toll in accordance with point 7 of Part B of the Tolling Regulations.

However, the on-board unit does not have to be presented at a GO point of sale, but the on-board unit number or the vehicle registration number valid for Austria and the country in which the vehicle

was registered must be disclosed. Otherwise there is a possibility of the offence of toll evasion (see point 10 of Part B of the Tolling Regulations).

1.7 Log out

Customers can deregister from the toll system at any time. However, deregistration must take the written form only. The letter of deregistration must be sent to:

ASFINAG Maut Service GmbH
z.H. ASFINAG Service Center
Am Europlatz 1
1120 Vienna

ASFINAG will then deactivate the on-board unit. Once this has happened, the on-board unit can no longer be used to pay tolls in Austria. The deactivation of the on-board unit is indicated by the sounding of a 'long' acoustic signal when the vehicle passes a toll collection point in Austria. Within ten days of deactivation, the OZD will send the holder of the registration certificate a chip card by post. The holder of the registration certificate is obliged to insert this chip card into the OBU immediately to reverse activation of the on-board unit. This will stop the unit from generating a 'long' signal when the vehicle passes a toll collection point in Austria.

2 SECOND CONTRACT INTEROPERABILITY WITH GERMANY ("TOLL2GO")

2.1 General information

Toll Collect GmbH (hereinafter also referred to as 'Toll Collect') on the one hand and ASFINAG, represented by ASFINAG Maut Service GmbH (hereinafter also referred to as 'ASFINAG'), on the other provide a service to customers that allows customers of both toll systems to use the German on-board unit (hereinafter referred to as 'TC OBU') to pay tolls in both the Federal Republic of Germany and in the Republic of Austria (hereinafter referred to as 'Toll2GO service'). The provision of the Toll2GO service does not affect the toll jurisdiction of either the Federal Republic of Germany or the Republic of Austria.

Payment of obligatory toll charges in Germany is still handled by Toll Collect and payment of obligatory toll charges in Austria is still handled by ASFINAG (dual contract interoperability).

2.2 Requirements for using the service in Austria

The applicant must be registered as a Toll Collect user and this registration must be active. They must also have a functioning TC OBU. This means that the TC OBU must have been provided by an existing Toll Collect service partner and correctly installed in the vehicle by the same in accordance with the relevant Toll Collect regulations before or at the latest by the time the application is submitted.

The TC OBU can only be used in Austria to pay tolls in conjunction with the post-pay procedure using the means of payment listed in Appendix 2. The TC OBU cannot be used in conjunction with the prepaid procedure.

In order to avail of this service, TC OBU users must register separately and correctly with ASFINAG (see section 2.3 for details).

In the following cases in particular, the TC OBU cannot be used to pay tolls in Austria:

- vehicles with vehicle registration numbers containing Cyrillic characters or other special characters;
- vehicles with an active Swiss on-board unit that is being used to pay tolls in Austria;
- vehicles with transferable license plates;
- vehicles with vehicle registration numbers issued in Austria before 2 January 1990 (i.e. vehicle license plate numbers with white characters on a black background);
- vehicles with metallised windscreens;
- in other cases where it is not possible to ensure that the toll is collected correctly.

In these cases, ASFINAG will make use of its right to refusal.

The simultaneous use of several on-board units that are authorised in Austria for electronic payment of the toll can lead to multiple payments of the toll and is, therefore, impermissible. Any toll overpayments due to this will not be refunded.

2.3 Registration

2.3.1 Registering for the first time

Customers who have not yet registered for the Austrian toll system may, if they wish, conclude an initial contract with ASFINAG regarding the use of the TC OBU instead of using an Austrian GO-Box. If they decide to conclude such a contract, they do not need to acquire an Austrian GO-Box. A non-refundable processing fee of €5 (incl. 20% VAT) per activated TC OBU and/or per TC OBU that has been cleared for use must be paid to access the system (to register with the toll system).

This requires that all the conditions set out below are met:

2.3.1.1 Registration procedure

Before the correctly installed TC OBU is used to pay Austrian tolls for the first time, the vehicle that is liable for the toll must be registered with the truck toll system in Austria.

Customers must register electronically as follows using the SelfCare Portal:

Customers can register electronically using the www.go-maut.at website. During the registration process, the customer must provide the following information, which will be saved by ASFINAG and used for the purpose of toll collection:

- Toll Collect user number
- country in which the vehicle was registered
- License plate number
- base category
- EURO emission class
- title
- name

- Street
- house number
- Post code
- town/city
- country of residence
- E-mail address
- Language
- Telephone number
- fax number
- card company
- card number (and possibly also the relevant card security code (CSC))
- valid until.

In order to use the TC OBU, the customer must accept Toll Collect's 'OBU-Einbuchung in Österreich' (OBU registration in Austria) conditions. The customer can accept these conditions on the SelfCare Portal. In the event of failure to give consent, the TC OBU cannot be used. In this case, the customer must use an Austrian GO-Box to pay the toll.

Once the customer has entered the required data, ASFINAG will transfer the following data to Toll Collect to complete the next stage of the registration process:

- Personal Account Number
- vehicle registration number and country where the vehicle was registered
- base category
- EURO emission class
- on-board unit identification number (OBU-ID)
- Toll Collect user number.

On the basis of the data transferred by ASFINAG, Toll Collect will check whether the conditions for using the TC OBU to pay tolls in Austria are met.

If the conditions are met, Toll Collect will initiate activation and clearance for use. Activation and clearance for use is an automatic process during which all relevant contractual data is entered in the TC OBU.

Following activation by Toll Collect, the vehicle registration numbers of those vehicles that have been cleared for use by Toll Collect for the Toll2GO service will be transferred to ASFINAG. The customer will be informed both in an e-mail from ASFINAG and in the SelfCare Portal of the fact that they can now use the TC OBU to pay tolls in Austria.

The fact that the OBU has been activated and cleared for use is also indicated on the TC OBU's display (for more information, please refer to the Toll Collect document 'Fahrzeuggerät Bedienungsanleitung' (On-board unit operating manual).

If Toll Collect finds that the conditions for using the TC OBU to pay tolls in Austria are not met, the customer will be informed by ASFINAG both in an e-mail and in the SelfCare Portal of the fact that the TC OBU cannot (at present) be used to pay tolls in Austria.

2.3.2 Switching from an Austrian GO-Box to the TC OBU

Customers that have already registered their vehicle for the toll system in Austria also have the option of paying the toll correctly using a TC OBU rather than the Austrian GO-Box.

In this case, the customer is obliged to return the Austrian GO-Box (see section 2.3.2.2) once the TC OBU has been activated and cleared for use. In this case, a processing fee does not have to be paid in order to activate/clear a TC OBU for use.

This requires that all the conditions set out below are met:

2.3.2.1 Registration procedure

Before the correctly installed TC OBU is used to pay Austrian tolls for the first time, the vehicle that is liable for the toll must be registered with the truck toll system in Austria.

Customers must register electronically using the SelfCare Portal on the www.go-maut.at website. In the SelfCare Portal, the customer will find a list of vehicles that can in principle be used with the TC OBU. Once the customer has entered their access data for the SelfCare Portal, they can select the vehicles listed in the SelfCare Portal for which they would like to use to TC OBU for toll payment. In order to use the TC OBU, the customer must accept Toll Collect's 'OBU-Einbuchung in Österreich' (OBU registration in Austria) conditions. The customer can accept these conditions on the SelfCare Portal. In the event of failure to give consent, the TC OBU cannot be used. In this case, the customer must use an Austrian GO-Box to pay the toll.

The customer is shown the data (vehicle registration number, country where the vehicle was registered, base category, and EURO emission class) for the vehicle registration number selected by the customer. Once the data has been entered, the customer cannot change the data (with the exception of the base category) themselves. For more information on the EURO emission class, please refer to section 2.3.3.

During the registration process, the customer can also change the means of payment used for the post-pay procedure or the type of contract (only from prepaid to post-pay) (see also section 2.6). On the basis of the data transferred by ASFINAG, Toll Collect will check whether the conditions for using the TC OBU to pay tolls in Austria are met.

For information on the subsequent stages of the verification, registration, and activation process, please refer to section 2.3.1.1 a).

2.3.2.2 Obligation to return the GO-Box

Once the TC OBU has been activated and cleared for use by Toll Collect, the customer is obliged to return the Austrian GO-Box to any GO point of sale. The customer will be informed of the obligation to return the GO-Box by two acoustic signals emitted by the TC OBU and four acoustic signals emitted by the Austrian GO-Box (see also section 2.12.3). If the customer does not comply with this obligation to return the GO-Box, ASFINAG reserves the right to deactivate the German on-board unit for payment of the toll in Austria too. Once this happens, the German on-board unit can only be re-activated by returning the GO-Box or by paying a non-refundable administrative fee of €60 at any GO point of sale.

2.3.3 Declaration of the relevant EURO emission class

2.3.3.1 General information

If the TC OBU is used for toll payment in Austria, all relevant contractual data shall be entered in the TC OBU in the course of activation and clearance for use. This means that for those cases where it is relevant for toll payment in Austria, only the EURO emission class for which evidence has been provided and which has been entered in the system for Austria will also be stored on the TC OBU.

As far as the EURO emission class is concerned, the following points must be observed:

a) Evidence of the EURO emission class has not yet been provided (e.g. in the case of registration for the first time)

It is important to determine whether the EURO emission class that is to be entered in the TC OBU is a EURO emission class for which evidence has to be submitted (i.e. EURO IV or better) or a EURO emission class for which no evidence is required (i.e. EURO I to III).

If the EURO emission class in question requires the submission of evidence, evidence of the EURO emission class must be provided before registration in accordance with section 5.2 of Tolling Regulations Part B. Otherwise a EURO emission class for which no evidence is required will be entered during the registration process. It is not possible to make an advance declaration at a GO point of sale.

In the case of a EURO emission class that requires the submission of evidence, Toll Collect can only be asked to enter the proven EURO emission class in the TC OBU for payment of the toll in Austria after ASFINAG has verified the submitted evidence.

Only the positive completion of the verification test and the actual deposit of the verified EURO emission class by Toll Collect on the TC OBU will give rise to a claim for the toll tariff assigned to the respective toll rate group.

b) Evidence of the EURO emission class has already been provided (e.g. switchover from the Austrian GO-Box to the TC OBU)

During activation and clearance for use, existing contractual data, data that has been provided by the customer, and the EURO emission class for which evidence has most recently been provided for Austria and entered in the system will be entered in the TC OBU. ASFINAG will instruct Toll Collect to enter data that is relevant to the contract and the proven EURO emission class in the TC OBU.

For those cases where a different EURO emission class has to be entered, please refer to section c) below.

Only the positive completion of the verification test and the actual deposit of the verified EURO emission class by Toll Collect on the TC OBU will give rise to a claim for the toll tariff assigned to the respective toll rate group.

c) Changing the EURO emission class

New evidence of a EURO emission class only has to be submitted in accordance with section 5.2 of Tolling Regulations Part B if the EURO emission class that has already been entered in the TC OBU has to be changed.

ASFINAG shall check the documents submitted as evidence.

Until such time as relevant documents are submitted as evidence to ASFINAG, tolls shall be paid on the basis of the EURO emission class that is already entered (and still stored) in the TC OBU.

Once the evidence has been verified, ASFINAG will instruct Toll Collect to enter the (new) proven EURO emission class in the TC OBU.

This means that in the case of a EURO emission class for which evidence has to be submitted, ASFINAG can only instruct Toll Collect to enter the proven EURO emission class in the TC OBU after the evidence has been verified.

Only the positive completion of the verification test and the actual deposit of the verified EURO emission class by Toll Collect on the TC OBU will give rise to a claim for the toll tariff assigned to the respective toll rate group.

2.3.4 Vehicle declaration

Following successful registration (i.e. once Toll Collect has activated the TC OBU and cleared it for use), the customer shall receive a vehicle declaration in accordance with section 5.2.1 of Tolling Regulations Part B.

Instead of the GO-Box identification number, the valid on-board unit identification number for Austria will be printed on the vehicle declaration.

If the stored vehicle data is changed in accordance with section 2.6, the original vehicle declaration will remain valid until such time as a new vehicle declaration is issued.

All vehicle declarations will be sent to the customer at the e-mail address provided by the customer. Moreover, the vehicle declaration can be obtained free of charge from a GO point of sale or the SelfCare Portal.

2.4 Right to refusal

Neither ASFINAG nor Toll Collect are obliged to approve use of the TC OBU for a specific vehicle. In fact, ASFINAG and Toll Collect have the right to refuse use either during the registration process or at a later date. If use is refused, the TC OBU cannot be used for toll payment in Austria. The right to assert claims against ASFINAG resulting from this refusal is expressly excluded.

2.5 The storage and exchange of data

When a customer registers, they expressly authorise Toll Collect and ASFINAG to exchange the data needed to allow the TC OBU to be used for toll payment in Austria. The following data is included in the exchange of information:

- general customer data such as the Toll Collect user number;
- technical data relating to the vehicle and the TC OBU insofar as the exchange of data is necessary for activation, clearance for use, and deactivation in accordance with sections 2.3.1 and 2.3.2;
- data needed for toll payment in Austria:
 - Blocking and unblocking of the TC OBU (blocking data is only exchanged to the extent that a blocking and/or unblocking affects the toll payment in Austria).
- statistical data for the purpose of quality measurement and quality analysis of the TC OBU:
 - - total number of successful MTRs
 - - individual data sets relating to retroactive billing (LSID, timestamp)
 - - individual data relating to tolls that were not collected (LSID, timestamp).

Should a customer, for any reason whatsoever, wish to revoke their authorisation to exchange data, such revocation shall be notified to ASFINAG and Toll Collect in writing, stating the vehicle registration number and personal account number (PAN for short) affected by such revocation within the meaning of 5.6.1 of Part B of the tolling regulations. After receipt of the revocation, the TC OBU will be blocked by ASFINAG for toll payment in Austria and the Toll2GO service will be deactivated by Toll Collect for the customer's affected vehicle license plates. Once the TC OBU has been deactivated for Austria, tolls must be paid using the Austrian GO-Box.

Please note that for the period between ASFINAG's receipt of the revocation and the actual deactivation by Toll Collect, the TC OBU will emit four brief acoustic signals whenever it passes a toll collection point. The TC OBU will only stop emitting acoustic signals once Toll Collect has completed the technical deactivation of the Toll2Go service.

2.6 Data changes

In derogation of section 5.6.2 of Tolling Regulations Part B, the following provisions apply to data changes:

a) Changing vehicle data

Changes must be sent to ASFINAG either via the SelfCare Portal or in writing. Registration at a GO point of sale is not possible.

b) Changing customer data

Customer data can only be changed in writing.

It is not possible to make customer data changes directly at a GO point of sale or in the SelfCare Portal.

c) Changing the means of payment

The means of payment is the only data change that can be made directly at a GO point of sale. The means of payment can also be changed in the SelfCare Portal or in writing. Please refer to Appendix 2.

Data changes that are submitted to ASFINAG in written form must be sent to the following address:

ASFINAG Maut Service GmbH
z.H. ASFINAG Service Center
Am Europlatz 1
1120 Vienna
Austria

On the basis of the changes made known by the customer, ASFINAG will instruct Toll Collect to make the relevant data changes to the TC OBU.

Data changes that are made known to Toll Collect only are not binding for ASFINAG. Customers should note that not making relevant data changes known constitutes a toll evasion offence in accordance with section 10. ASFINAG will make every effort to enter data changes about which it subsequently finds out (especially changes to vehicle registration numbers). However, such changes will not have any effect on breaches of administrative rule that have already been committed.

2.7 The sale or rental of vehicles

The provisions in section 5.6.4.2 of Tolling Regulations Part B apply accordingly to the rental of vehicles.

If the holder of a registration certificate sells their vehicle, for which a TC OBU has been activated and cleared for use, they are obliged to inform ASFINAG of this fact in writing. If they do not do so, the holder of the registration certificate shall assume sole responsibility for the billing and payment of future Austrian toll transactions. The announcement of the sale is regarded as a written cancellation of the TC OBU, so it can no longer be used for toll payment in Austria (see point 2.10 Cancellation).

Before using the Austrian road network subject to tolls for the first time, the buyer of the vehicle is obliged to make a new registration for the toll system.

2.8 Provisions relating to the TC OBU

Toll Collect GmbH is the sole contact for matters relating to the TC OBU:

Toll Collect GmbH
PO Box 11 03 29
D-10833 Berlin
Germany

The relevant Toll Collect provisions shall apply to the installation, exchange, and return of the TC OBU. If the TC OBU is used to pay tolls in Austria, the driver must make sure that Toll Collect's conditions regarding installation and use are observed. In particular, the driver must make sure that the area above the DSRC module as well as an area 190 mm from the driver's side and 70 mm from the front-seat passenger are kept clear.

For this reason, all claims relating to the TC OBU should be addressed to Toll Collect, especially those claims relating to the provision of maintenance, repair, and exchange services. These services are provided either directly by Toll Collect or by a Toll Collect service partner.

In the event of theft, loss, and deactivation, section 5.7.3 of Tolling Regulations Part B shall apply accordingly, whereby in this case, no administrative fee is payable to ASFINAG.

Generally speaking, because the TC OBU is securely installed in the vehicle, it cannot be removed by either ASFINAG or the customer. In those cases where, in accordance with the provisions of Tolling Regulations Part B, the on-board unit has to be presented (in particular at the GO points of sale), customers using a TC OBU must provide the on-board unit identification number that is valid for Austria, the vehicle registration number, and the country where the vehicle was registered.

Both ASFINAG and Toll Collect are entitled to deactivate the TC OBU in the event of technical faults or if they discover irregularities in the collection of tolls. The TC OBU will be deactivated should certain technical error patterns arise (e.g. an accumulation of instances where tolls could not be correctly collected, incomplete transaction data etc.). If the TC OBU is deactivated, the driver will be notified of this fact by the sounding of four acoustic signals.

2.9 GO points of sale

GO points of sale are available to customers using the TC OBU for the following services in particular:

- Acceptance of retroactive payments
- the return of Austrian GO-Boxes;
- Change in the postpaid means of payment
- the issuing of Austrian GO-Boxes;
- the conclusion of rental contracts;
- information about the status of the TC OBU;
- Issue of vehicle declarations
- the payment of administrative fees.

2.10 Deregistering the TC OBU

One or more TC-OBUs can be deregistered for toll payment in Austria in writing at any time. The letter of deregistration must be sent to the following address:

ASFINAG Maut Service GmbH
z.H. ASFINAG Service Center
Am Europlatz 1
1120 Vienna
Austria

Customers can also deregister their TC OBUs via the SelfCare Portal.

Once ASFINAG has received the letter of deregistration, ASFINAG will immediately deactivate the TC OBU for toll payment in Austria. ASFINAG shall inform the customer by e-mail about the completion of the deregistration process. From this point on, toll in Austria must be paid using an Austrian GO-Box.

ASFINAG shall inform Toll Collect about the deregistration. Toll Collect shall immediately initiate the necessary deactivation of the Toll2GO service on the TC OBU. Please note that for the period between ASFINAG's receipt of the revocation and the actual deactivation by Toll Collect, the TC OBU will emit four brief acoustic signals whenever it passes a toll collection point. The TC OBU will only stop emitting acoustic signals once Toll Collect has completed the technical deactivation of the service.

Customers should note that Toll Collect is also entitled to exclude the TC OBU from being used for toll payment in Austria. The customer must make sure in good time that tolls can be paid correctly in Austria, if necessary using an Austrian GO-Box. Customers should note that they are obliged to pay toll retroactively in accordance with section 7 of Tolling Regulations Part B.

As soon as Toll Collect informs ASFINAG that a TC OBU has been excluded, ASFINAG will inform the customer by e-mail and via the SelfCare Portal.

ASFINAG is not obliged to check whether Toll Collect's decision to exclude the TC OBU is legitimate and is not responsible for doing so.

2.11 Subsequent payment of the toll

In the event of improper toll payment, the customer shall pay the toll in accordance with point 7 of Part B of the Tolling Regulations. Both in the case of subsequent payment at a GO point of sale, for a toll enforcement officer and in the case of central subsequent payment, the on-board unit number valid for Austria, the vehicle license plate number and the country in which the vehicle was registered must be disclosed.

Section 7 of Tolling Regulations Part B applies with the proviso that it is not possible to obtain information about toll transactions at GO points of sale because the TC OBU is securely installed in the vehicle and cannot, therefore, be presented at a GO point of sale.

For all details on the authorised means of payment, please refer to Appendix 2 of the Tolling Regulations.

2.12 Obligations of motor vehicle drivers

2.12.1 The correct installation and operation of the TC OBU and setting the category in the TC OBU

The proper installation and operation of the TC OBU as well as the setting of the category is governed by the applicable operating regulations of Toll Collect. For this reason, the TC OBU must be installed and kept operable in accordance with Toll Collect's standards.

If a trailer or a road semi-trailer is attached to the vehicle, the vehicle driver must set the vehicle category in the TC OBU in accordance with the Toll Collect document 'Fahrzeuggerät Bedienungsanleitung' (On-board unit operating manual) before using the road network subject to tolls. The actual number of axles of the tractor unit together with the number of axles of the (semi-)trailer, regardless of the maximum total weight of the (semi-)trailer, determines the category that is to be set. The declared number of axles can be read on the display of the TC OBU.

2.12.2 Checking that the TC OBU is in working order

Once the TC OBU has been activated and cleared for use, the vehicle driver must check before the start of every journey whether the TC OBU is working properly and whether toll payment in Austria is possible.

For more information on how to do so, please refer to the Toll Collect document 'Fahrzeuggerät Bedienungsanleitung' (On-board unit operating manual).

In the event that the toll payment in Austria cannot be made with the TC OBU, the customer shall be obliged to use an Austrian GO-Box in accordance with Part B of the tolling regulations. The Austrian GO-Box can be obtained at any GO point of sale. It is expressly pointed out that the driver of the motor vehicle must in particular ensure that when changing to the Austrian GO-Box they also fulfil their obligations to pay the toll in accordance with point 2.11. This is a very important point because failure to do so (i.e. failure to pay accrued tolls after switching to a GO-Box) can constitute a toll evasion offence in accordance with section 10 of Tolling Regulations Part B.

2.12.3 Acoustic signals emitted by the TC OBU

Vehicle drivers must pay attention to the acoustic signals emitted by the TC OBU while on the move. In case of irregularities, the nearest GO point of sale should be contacted, where an Austrian GO-Box can be obtained and an obligation to make additional payments as defined in point 2.11 Part C of the tolling regulations can be fulfilled.

In accordance with section 8.2.4.3 of Tolling Regulations Part B, the customer must observe the following acoustic signals emitted by the TC OBU, each of which is associated with different obligations:

- **ON short signal tone (beep)**

This signal means that toll payment is confirmed on the basis of the set category (number of axles) and the EURO emission class stored in the on-board unit.

- **TWO brief acoustic signals (beeps)**

Here too, the sounding of two beeps means that the toll has been paid on the basis of the set category (number of axles) and the EURO emission class stored in the on-board unit. TWO short beeps mean that the driver is requested to contact the nearest GO point of sale. The customer will be informed directly at the GO point of sale about the further procedure (to be followed by them) (e.g. information that it is necessary to return a GO-Box).

Please note that a failure to observe this request can lead to the automatic deactivation of the on-board unit for toll payment in Austria.

- **FOUR short acoustic signals (beeps)**

The sounding of four beeps means that the toll was not paid correctly (e.g. four beeps are sounded when the on-board unit has been deactivated or alert the driver to a faulty transaction). In this case, the customer is obliged in accordance with section 2.11 to go to a GO point of sale within 5 hours and 100 kilometres and to retroactively pay the toll for the relevant toll sections.

- **NO acoustic signal (no beep)**

No beep means that no toll was paid (e.g. when a transaction was not completed because of a technical error). The only time when the customer is not obliged to retroactively pay the toll in accordance with section 7 of Tolling Regulations Part B is when the preconditions of section 8.2.4.3.3 of Tolling Regulations Part B are met.

- **Carrying both a TC OBU and an Austrian on-board unit in the vehicle simultaneously**

If a vehicle contains both the TC OBU and the Austrian GO-Box simultaneously, it is possible that one of these two on-board units might indicate by sounding four beeps that the toll was not paid. There is no obligation to make a subsequent payment according to point 2.11 only if the toll has been properly paid by the other on-board unit, which is indicated by one or two short beeps.

3 THE AUTHORISATION OF ON-BOARD UNITS ACTIVATED FOR THE EASYGO+ SERVICE

3.1 General information

Together, the members of the EasyGo toll consortium (which comprises toll operators from Denmark, Norway, Sweden, and Austria) have succeeded in implementing a single-contract interoperability solution for motor vehicles with a maximum total weight (GVW) of more than 3.5 t. Hereinafter this service shall be referred to as the 'EasyGo+ service'.

If used properly, the EasyGo+ service allows service users to pay the distance-related toll in Austria and the toll at various points in Denmark, Sweden, and Norway using a single on-board unit (hereinafter referred to as the 'EasyGo+ OBU') that has been activated for the EasyGo+ Service .

It is expressly pointed out at this point that toll payment in Austria for vehicles over 3.5 t MPW is only possible for the service user if the EasyGo+ service has been activated. Please also note that it is not possible to pay the toll in Austria if using the EasyGo Service (regardless of the maximum GVW of the motor vehicle).

For a list of toll (point) operators and for other useful information on the EasyGo and/or EasyGo+ services, please visit <http://www.easygo.com>. ASFINAG does not assume any responsibility or liability for the timeliness, correctness, and completeness of the information given on <http://www.easygo.com>, which can be amended, supplemented, or removed without prior notice at any time.

3.2 Provisions relating to the on-board unit (hereinafter referred to as the EasyGo+ OBU)

The EasyGo+ OBU can only be obtained from and returned to toll service providers who provide the EasyGo+ service and as long as the EasyGo+ OBU is authorised for toll payment in Austria.

In accordance with section 7 BStMG, the EasyGo+ OBU can currently be authorised for toll payment in Austria by:

- **'BroBizz+'**, as long as the EasyGo+ service is used on this OBU and is activated by the toll service provider BroBizz A/S;

Service users must direct all questions regarding the EasyGo+ OBU to their respective toll service providers. For this reason, all claims relating to the EasyGo+ OBU must be addressed to the toll service provider, especially those claims relating to the provision of maintenance, repair, and exchange services.

The EasyGo+ OBU must be operated and kept serviceable in accordance with the instructions of the toll service provider. For instructions on the attachment and operation of the EasyGo+ OBU, please refer to section 3.5.2.

The simultaneous use in a single motor vehicle of several on-board units that are authorised for electronic toll payment in Austria can lead to multiple toll payments. In this case, ASFINAG is not obliged to refund the excess toll payments.

3.3 Registering with and de-registering from the EasyGo+ service

Toll service providers alone are responsible for organising the registration with/de-registration from the EasyGo+ service. In other words, service users must contact their respective toll service providers in order to register with/de-register from the EasyGo+ Service.

It must be noted that ASFINAG is not responsible for providing and verifying evidence in connection with the EURO emission class when using an EasyGo+ OBU. An additional provision of evidence at ASFINAG by the service user is not required. However, ASFINAG has the right to ask the toll service provider to provide the documents that were submitted as evidence and used to determine the EURO emission class (for which evidence must be provided) that has been stored on the EasyGo+ OBU. The toll service provider is obliged to comply with this request. However, when using the EasyGo+ service, service users are obliged to check the vehicle declaration provided by the toll service provider and to carry both this declaration and the relevant evidence (in accordance with Part B, section 5.2.3) in the vehicle at all times in order to ensure that the allocation of a EURO emission class to a toll rate group can be verified at any time.

If – for whatever reason or at whatever time – a service user has used a 'local' Austrian GO-Box or another authorised on-board unit other than the EasyGo+ OBU (e.g. TC OBU, Emotach) to pay the toll in Austria, uses them simultaneously, or intends to use one in the future, the relevant processes and the obligation to provide timely and correct evidence of the EURO emission class in accordance with Part B and Part C (sections 1 and 2) remain unaffected.

3.4 The storage and exchange of data

When a service user uses the EasyGo+ service for toll payment in Austria, they expressly authorise ASFINAG and the toll service provider to exchange, store, and process the data needed to allow the EasyGo+ OBU

- a) to ensure and carry out the toll payment in Austria or
- b) to sanction any potential violations of the prohibition to use the road network subject to tolls without paying the toll properly.

3.4.1 Correct toll payment with the EasyGo+ OBU

In order to ensure that the EasyGo+ OBU can be used for toll payment in Austria, ASFINAG stores, processes, and exchanges the following data in particular:

- vehicle-specific data
 - Vehicle license plate number and country of registration
 - EURO emission class
 - base category
 - European Vehicle Group
- Personal Account Number (PAN)
- on-board unit identification number (EasyGo+ OBU ID)
- relevant toll service provider
- type of contract (stored by the toll service provider)
- data for the de-activation and re-activation of the EasyGo+ OBU by the toll service provider

- data for toll billing
 - successfully collected tolls
 - unsuccessfully collected tolls
 - retroactively billed and collected tolls
 - toll section used
 - time the toll section was used

By using the EasyGo+ service, the service user accepts that ASFINAG stores and processes the data listed above and exchanges this data with the relevant toll service provider for the purpose of toll charging, quality measurement, and quality analysis.

3.4.2 Incorrect toll payment with the EasyGo+ OBU

If the toll is not correctly paid (see in particular Part B, section 10: 'Toll evasion'), the toll service provider sends ASFINAG the data required to send the holder of the registration certificate a written request to pay the substitute toll or the information letter pursuant to Section 30b para. 1 BStMG or to initiate administrative penal proceedings.

3.5 Obligations

3.5.1 Vehicle declaration

Before using the Austrian network of motorways and expressways, the service user is obliged to check whether:

- the vehicle registration number attached to the vehicle and the country where the vehicle was registered and
- the OBU ID on the EasyGo+ OBU

are the same as those given in the vehicle declaration.

If they are not or if no valid EasyGo+ service contract has been concluded, the service user must refrain from their intention to pay the toll using the EasyGo+ OBU. Failure to comply with this provision can constitute a toll evasion offence (see section 10 of Tolling Regulations Part B).

In this case it is possible to pay the toll using the "local", Austrian GO-Box according to part B of the tolling regulations (see also point 3.8).

Moreover, the service user is obliged to carry the vehicle declaration they received from the toll service provider and to show both this declaration and the documents that allow for verification of the allocation of a EURO emission class to a toll rate group (in accordance with Part B, section 5.2.3) to officers in the event of an inspection.

If the service user needs to change any data (especially toll rate-related data), they must contact the relevant toll service provider (see also section 3.7).

3.5.2 Installation and operation of the EasyGo+ OBU

The EasyGo+ OBU must be operated and kept serviceable in accordance with the instructions of the toll service provider. The EasyGo+ OBU must be installed in accordance with the instructions of the toll service provider and, when using the Austrian road network subject to tolls, in accordance with the regulations for the correct installation of the 'local' Austrian GO-Box (see in particular

section 8.1 of Tolling Regulations Part B). Otherwise there is a possibility of the offence of toll evasion (see point 10 of Part B of the Tolling Regulations).

3.5.3 Declaring and setting the category

Before the start of every journey, the service user must check and set the category. For the declaration of the category to be set, the actual number of axles of the tractor unit together with the number of axles of the (semi-)trailer is decisive, regardless of the maximum permissible total weight of the (semi-)trailer.

The axles of a trailer are not taken into account when setting the number of axles for buses and caravans.

3.5.4 Checking that the EasyGo+ OBU is in working order

The service user must check that the EasyGo+ OBU is in working order before, during, and at the end of every trip. If toll payment in Austria is/was not possible with the EasyGo+ OBU, the service user should use a 'local' Austrian GO-Box (see also section 3.8). It is expressly pointed out that in the event of improper toll payment, the service user must comply with their obligations to pay the toll in accordance with Section 3.6. Failure to comply with this obligation can constitute a toll evasion offence in accordance with section 10 of Tolling Regulations Part B.

3.5.5 Acoustic signals emitted by the EasyGo+ OBU

Service users must pay attention to the acoustic signals emitted by the EasyGo+ OBU while on the move. In the event of irregularities, the service user must visit the nearest GO-Box point of sale where they can obtain a "local", Austrian GO-Box (see also point 3.8) and meet their obligation to make subsequent payments (see also point 3.6). In accordance with section 8.2.4.3 of Tolling Regulations Part B, the customer must observe the following acoustic signals emitted by the EasyGo+ OBU, each of which is associated with different obligations on the part of the service user:

- **ON** short signal tone (beep)
One beep means that toll payment is confirmed on the basis of the set category (number of axles) and the EURO emission class stored in the EasyGo+ OBU.
- **TWO** short signal tones (beeps)
Two beeps means that toll payment is confirmed on the basis of the set category (number of axles) and the EURO emission class stored in the EasyGo+ OBU. The toll service provider will be happy to provide information on any service user obligations.
- **FOUR** short acoustic signals (beeps)
FOUR beeps means that the toll was not correctly paid. In this case, the service user is obliged in accordance with section 3.6 to go to a GO point of sale and to retroactively pay the toll for the relevant toll sections. They should also use a 'local' Austrian GO-Box before continuing the journey on the road network subject to tolls (see also section 3.8).
- **NO** signal tone (beeps)
No beep means that no toll payment has taken place. The only time when the customer is not obliged to retroactively pay the toll in accordance with section 3.6 of Tolling Regulations

Part C is when the preconditions outlined in section 8.2.4.3.3 of Tolling Regulations Part B are met.

3.6 Subsequent payment of the toll

In the event of incorrect toll payment, the service user shall pay the toll in accordance with Section 7 Tolling Regulations Part B. Otherwise there is a possibility of the offence of toll evasion (see point 10 of Part B of the Tolling Regulations). The following specific provisions apply when using the EasyGo+ service:

- The EasyGo+ OBU must not be presented at a GO point of sale. Alternatively, the vehicle license plate number and the country in which the vehicle was registered can be disclosed.
- It is not possible to obtain information about toll transactions at a GO point of sale.
- If the category used was too low, central retroactive payment can only be made by calling the ASFINAG Service Center by telephone.
- Retroactive payment is made directly to ASFINAG (in other words not via the toll service provider). For all details on the authorised means of payment, please refer to Appendix 2 of the Tolling Regulations.
- No provisions are made for retroactive payment in conjunction with the EURO emission class because the toll service provider will already have checked the EURO emission class.

3.7 Responsibilities and services

3.7.1 Toll service providers

As a rule, the service user must always contact their toll service provider first. Service users must therefore always contact the service provider in the following exemplary cases:

- registration with and de-registration from the EasyGo+ service;
- handover and personalisation of an EasyGo+ OBU;
- Verification of the EURO emission class
- Issue of vehicle declarations
- Payment procedures, especially accounting and information
- Data changes, in particular vehicle data, data of the service user, means of payment
- de-activation and re-activation of the EasyGo+ OBU (e.g. in the event of the loss of the EasyGo+ OBU);
- maintenance, repair, and exchange services relating to the EasyGo+ OBU;
- information regarding the sale or rental of vehicles using the EasyGo+ service.

3.7.2 GO points of sale

GO points of sale are available to users of the EasyGo+ service in the following cases in particular:

- Acceptance of retroactive payments
- Output of "local", Austrian GO-Boxes

- Receipt of (possibly) returned "local" Austrian GO-Boxes

3.7.3 ASFINAG SERVICE CENTER (ASC)

Service users can call the ASC using one of the following numbers: 0800 400 12 400 (when calling from inside Austria) or +43 1 955 12 66 (when calling from outside Austria). The ASC is on hand to take central retroactive payments in the event of the use of the wrong category (number of axles) and to answer any general questions and issues relating to the Austrian toll system.

3.7.4 Special features

Service users cannot use the services and functions of the SelfCare Portal. Likewise, ASFINAG Maut Service GmbH shall not provide the service user with individual service information or a collective invoice (in accordance with item 6 of Part B of the Tolling Regulations). The services available depend on the respective toll service provider. The service provider reserves the right to amend the type and scope of these services.

3.8 Use of the "local" Austrian GO-Box

In the event that the EasyGo+ OBU cannot be used to pay the toll in Austria, the service user is obliged to use a "local" Austrian GO-Box in accordance with the Tolling Regulations Part B. The "local" Austrian GO-Box can be obtained at any GO point of sale. It is expressly pointed out that the service user must ensure in particular that when switching to the "local", Austrian GO-Box they also meets their obligations to pay the toll in accordance with point 3.6 of part C and point 7 of part B of the tolling regulations. This is important because failure to comply with these obligations (changeover, subsequent payment) may constitute toll evasion in accordance with point 10 of Part B of the tolling regulations.

In the following cases in particular, the toll in Austria must be paid using a 'local' Austrian GO-Box:

- if the EasyGo+ OBU experiences a technical failure;
- if the EasyGo+ OBU is de-activated;
- if the data on the vehicle declaration is not the same as the registration number attached to the vehicle, the country in which the vehicle was registered, and the OBU ID of the EasyGo+ OBU.

It is expressly pointed out that the simultaneous use of several on-board units registered in Austria for electronic payment in the same toll vehicle can lead to multiple toll debits. In this case, ASFINAG is not obliged to refund the excess toll payments.

4 THE AUTHORISATION OF ON-BOARD UNITS FOR TOLL PAYMENT IN AUSTRIA WITHIN THE SCOPE OF THE “EUROPEAN ELECTRONIC TOLL SERVICE” (“EETS”)

4.1 European Electronic Toll Service (EETS)

In accordance with Directive 2019/520 of 19 March 2019 and the associated Implementing Regulation EU 2020/204 and Delegated Regulation EU 2020/203 of 28 November 2019, the specifications for the EETS Domain of Autobahnen- und Schnellstraßen- Finanzierungs- Aktiengesellschaft (hereinafter "EETS Domain Statement"), as amended from time to time, are published on ASFINAG's website (at www.asfinag.at) pursuant to section 7 BStMG.

The EETS Domain Statement is an appendix (see Appendix 9) to the present tolling regulations and is deemed to be an integral part of the European Electronic Toll Service (EETS).

The following provisions apply to customers of EETS providers ("EA") who are authorised to operate in ASFINAG's EETS domain. The EETS domain of ASFINAG comprises the federal roads (motorways and expressways) in Austria that are subject to tolls. The provisions also apply mutatis mutandis to customers of approved service providers who have an existing REETS contract with ASFINAG. For the sake of better readability, only the terms EETS or EA will be used in the following.

ASFINAG is the toll charger in Austria in connection with the provision of EETS.

If the on-board unit (hereinafter also referred to as EETS-OBU) has been approved by ASFINAG for toll payment in Austria, it shall be made available to the customer (hereinafter referred to as "EETS User") by the EA.

Toll payment in Austria for vehicles over 3.5 t MPW is only possible for customers if the EETS OBU is activated for the EETS domain of ASFINAG.

4.2 Provisions relating to the on-board unit (EETS OBU)

An EETS OBU can only be obtained and returned from those EAs that also offer EETS for ASFINAG's EETS domain and whose EETS OBU is approved for toll payment in Austria.

EETS OBUs that are authorised for toll payment in accordance with section 7 BStMG may, if EETS should be used, be authorised by the EA for toll payment in Austria.

The EAs authorised to pay tolls are listed in Appendix 2.

The sole contact person for the EETS User in connection with the EETS OBU is the respective EA of the EETS User. All claims regarding the EETS OBU are therefore to be brought against the EA, especially in relation to the rendering of maintenance, repair and replacement services.

The EETS OBU must be operated and kept serviceable in accordance with the instructions of the EA. With regard to the EETS User's obligations to cooperate in ASFINAG's EETS domain, reference is made in particular to point 4.5.

4.3 Registration with and de-registration from EETS

Registration with and de-registration from EETS falls solely within the remit of the respective service provider and is to be arranged between the service provider and the EETS user.

The provision and verification of evidence in connection with the EURO emission class when using an EETS OBU is not the responsibility of ASFINAG. An additional provision of evidence at ASFINAG by the EETS user is not required. However, ASFINAG has the right to request from the EA those documents that were submitted as evidence and used to determine the EURO emission class that was stored on the EETS OBU. The EA is obliged to comply with this request. However, when using EETS, the EETS user is required to check the vehicle declaration submitted by the EA and to carry it in the motor vehicle together with the required evidence (in accordance with Part B, section 5.2.3) in order to make it possible to verify the allocation of a EURO emission class to a rate group.

4.4 The storage and exchange of data

By using EETS to pay tolls in Austria, the EETS User acknowledges that ASFINAG and the EA exchange, store and further process the data that is required for the EETS OBU to be able to communicate with ASFINAG and the EA.

- a) to ensure and carry out the toll payment in Austria or
- b) any violations of the prohibition to use the road network subject to tolls without properly paying the toll (toll evasion within the meaning of section 20 of the Federal Roads Toll Act) can be punished.

ASFINAG and the EA each act independently as data protection controllers.

4.4.1 Correct toll payment with the EETS OBU

In order to ensure that the EETS OBU can be used for toll payment in Austria, ASFINAG stores, processes and exchanges the following data in particular with the EA:

- vehicle-specific data
- Personal Account Number (PAN)
- on-board unit identification number (EETS OBU ID)
- Responsible EA
- data for deactivation and re-activation of the EETS OBU by the EA
- data for toll billing

By using EETS, the EETS User acknowledges that the above-mentioned data may be stored, processed and exchanged with the respective EA by ASFINAG for the purposes of toll billing and quality measurement and analysis.

4.4.2 Incorrect toll payment with the EETS OBU

If the toll is not correctly paid (see in particular Part B, section 10 “Toll evasion”), the EA may provide ASFINAG with the data required to send the holder of the registration certificate a written request to pay the substitute toll or to initiate administrative penal proceedings.

4.5 Obligations

4.5.1 Vehicle declaration

Before using the Austrian network of motorways and expressways, the EETS user is obliged to check whether:

- the vehicle registration number attached to the vehicle and the country where the vehicle was registered and
- the on-board unit number (OBU-ID) indicated on the EETS OBU

are the same as those given in the vehicle declaration.

If they are not or no valid EETS contract has been concluded, the service user must refrain from their intention to pay the toll using the EETS OBU. Failure to comply with this provision can constitute a toll evasion offence (see section 10 of Tolling Regulations Part B).

In this case it is possible to pay the toll using the Austrian GO-Box according to part B of the tolling regulations (see also point 4.8).

Moreover, the service user is obliged to carry the vehicle declaration they received from the EA and to show both this declaration and the documents that allow for verification of the allocation of a EURO emission class to a toll rate group (in accordance with Part B, section 5.2.3) to officers in the event of an inspection.

If the service user needs to change any data (especially toll rate-related data), they must contact the relevant EA (see also section 4.7).

4.5.2 Installation and operation of the EETS OBU

The EETS OBU must be operated and kept serviceable in accordance with the instructions of the EA. The EETS OBU must be installed in accordance with the instructions of the EA and, when using the Austrian road network subject to tolls, in accordance with the regulations for the correct installation of the Austrian GO-Box (see in particular section 8.1 of Tolling Regulations Part B). Otherwise there is a possibility of the offence of toll evasion (see point 10 of Part B of the Tolling Regulations).

4.5.3 Declaring and setting the category

Before the start of every journey, the EETS user must check and set the category. For the declaration of the category to be set, the actual number of axles of the tractor unit together with the number of axles of the (semi-)trailer is decisive, regardless of the maximum permissible total weight of the (semi-)trailer.

The axles of a trailer are not taken into account when setting the number of axles for buses and caravans.

4.5.4 Checking that the EETS OBU is in working order

The EETS user must check whether the EETS OBU is in working order before, during, and at the end of every trip. In the event that the EETS OBU cannot or could not be used to pay the toll in Austria, an Austrian GO-Box should be used (see also point 3.8). It is expressly pointed out that in the event of improper toll payment, the EETS user must comply with their obligations to pay the toll retroactively in accordance with Section 4.6. Failure to comply with this obligation can constitute a toll evasion offence in accordance with section 10 of Tolling Regulations Part B.

In the event that several EETS OBUs are used for one vehicle, the EETS user must ensure prior to each trip that only one single on-board unit is active for toll payment in Austria. Please note that the simultaneous use of several on-board units that are authorised for electronic toll payment in Austria can lead to multiple toll payments. In this case, ASFINAG is not obliged to refund the excess toll payments.

4.5.5 Acoustic signals emitted by the EETS OBU

EETS users must pay attention to the acoustic signals emitted by the EETS OBU while on the move. In the event of irregularities, the EETS user must visit the nearest GO point of sale where they can obtain an Austrian GO-Box (see also point 4.8) and meet their obligation to make subsequent payments (see also point 4.6).

In accordance with section 8.2.4.3 of Tolling Regulations Part B, the customer must observe the following acoustic signals emitted by the EETS OBU, each of which is associated with different obligations on the part of the EETS user:

- **ONE** short signal tone (beep)
One beep means that toll payment is confirmed on the basis of the set category (number of axles) and the EURO emission class stored in the EETS OBU.
- **TWO** short signal tones (beeps)
Two beeps means that toll payment is confirmed on the basis of the set category (number of axles) and the EURO emission class stored in the EETS OBU. The EA will be happy to provide information on any EETS user obligations.
- **FOUR** short acoustic signals (beeps)
FOUR beeps means that the toll was not correctly paid. In this case, the EETS user is obliged in accordance with section 4.6 to go to a GO point of sale and to retroactively pay the toll for the relevant toll sections. The EA will give information about any action that the EETS user is required to take, such as the replacement of the EETS OBU.
- **NO** signal tone (beeps)
No beep means that no toll payment has taken place. The only time when the customer is not obliged to retroactively pay the toll in accordance with section 4.6 of Tolling Regulations Part C is when the preconditions outlined in section 8.2.4.3.3 of Tolling Regulations Part B are met. The EA will give information about any action that the EETS user is required to take, such as the replacement of the EETS OBU or the correct installation and operation of the EETS OBU.

4.6 Subsequent payment of the toll

In the event of incorrect toll payment, the EETS user shall pay the toll in accordance with Section 7 Tolling Regulations Part B. Otherwise there is a possibility of the offence of toll evasion (see point 10 of Part B of the Tolling Regulations). The following specific provisions apply when using EETS:

The EETS OBU must not be presented at a GO point of sale. Instead, the vehicle declaration must be presented as a means of identification. Alternatively, the vehicle license plate number and the country in which the vehicle was registered can be disclosed.

It is not possible to obtain information about toll transactions at a GO point of sale.

Retroactive payment of the toll at a GO point of sale is made only on request and in accordance with the information provided by the EETS user (in particular toll sections used but not correctly paid for, number of axles, EURO emission class), as only the EETS user can determine when and where a toll was not paid.

If the category used was too low, central retroactive payment can only be made by calling the ASFINAG Service Center by telephone.

Retroactive payment is made directly to ASFINAG (in other words not via the EA). For all details on the authorised means of payment, please refer to Appendix 2 of the Tolling Regulations.

No provisions are made for retroactive payment in conjunction with the EURO emission class because the EA will already have checked the EURO emission class.

In the event of an unsuccessful transaction by the EETS User, retroactive payment of the toll is in principle possible at GO points of sale and to toll enforcement officers in Austria using the means of payment accepted there, but not via the means of payment used within the scope of EETS (=EETS means of payment). The retroactive payment must be made in accordance with the specifications in the Tolling Regulations. In addition, there is the possibility of central retroactive payment if a category is used that is too low or an incorrect emission class in accordance with the specifications in the tolling regulations.

4.7 Responsibilities and services

4.7.1 EA

As a rule, the EETS user must always contact their EA first. EETS users must therefore always contact the service provider in the following exemplary cases:

- Registration with and de-registration from EETS
- Handover and personalisation of the EETS OBU
- Verification of the EURO emission class
- Issue of vehicle declarations
- Payment procedures, especially accounting and information
- Data changes, in particular vehicle data, data of the EETS user, means of payment
- De-activation and re-activation of the EETS OBU (e.g. in the event of the loss of the EETS OBU)
- Maintenance, repair, and exchange services relating to the EETS OBU
- Information regarding the sale or rental of vehicles using EETS

4.7.2 GO points of sale

GO points of sale are available to users of EETS in the following cases in particular:

- Acceptance of retroactive payments
- Issuance of Austrian GO Boxes
- Receipt of (possibly) returned "local" Austrian GO-Boxes

4.7.3 ASFINAG Service Center (ASC)

EETS users can call the ASC using one of the following numbers: 0800 400 12 400 (when calling from inside Austria) or +43 1 955 12 66 (when calling from outside Austria). The ASC is on hand to take central retroactive payments in the event of the use of the wrong category (number of axles) and to answer any general questions and issues relating to the Austrian toll system.

4.7.4 Special features

EETS users cannot use the services and functions of the SelfCare Portal. Likewise, ASFINAG Maut Service GmbH shall not provide the EETS user with individual service information or a collective invoice (in accordance with item 6 of Part B of the Tolling Regulations). The services available depend on the respective EA. The EA reserves the right to amend the type and scope of these services.

4.8 Use of the Austrian GO-Box

In the event that the EETS OBU cannot (properly) be used for toll payment in Austria, the EETS user is obliged to use an Austrian GO-Box or another on-board unit approved in ASFINAG's EETS domain. The Austrian GO-Box can be obtained at any GO point of sale. It is expressly pointed out that the EETS user must ensure in particular that when switching to the Austrian GO-Box they also meet their obligations to pay the toll in accordance with point 4.6 of part C and point 7 of part B of the Tolling Regulations. This is important because failure to comply with these obligations (changeover, retroactive payment) may constitute toll evasion in accordance with point 10 of Part B of the tolling regulations.

In the following cases in particular, the toll in Austria must be paid using an Austrian GO-Box:

- if the EETS OBU experiences a technical failure;
- if the EETS OBU is de-activated;
- if the data on the vehicle declaration is not the same as the registration number attached to the vehicle, the country in which the vehicle was registered, and the OBU ID of the EETS OBU.

Please note that the simultaneous use of several on-board units that are authorised for electronic toll payment in Austria can lead to multiple toll payments. In this case, ASFINAG is not obliged to refund the excess toll payments. However, if two or more on-board units are installed or carried in a vehicle, the EETS user is responsible for using or activating the corresponding on-board units for the specific EETS domain.